

Light at eye level is a means to create energy savings and space for learning, focus and concentration

Ansøgte støtteprogram	ELFORSK
Ansøger (virksomhed)	Henning Larsen
Projektnummer	349-062
Projekttitel: (dansk)	Lys i øjenhøjde skaber energibesparelse og rum til læring, fokus og fordybelse
Projekttitel engelsk	Light at eye level is a means to create energy savings and space for learning, focus and concentration
Indsatsområde	Belysning/LED-belysning



Authors:

Imke Vies van Mill

Anne Iversen

Werner Osterhaus

Maria Garcia Alvarez

Steffen Petersen

Cheol-Ho Jeong (Sound chapter, financially supported by Dansk Lyd)

Table of Contents

1. RESUME (DANSK)	4
2. OVERVIEW	6
2.1.1.1. AIM.....	6
2.1.1.2. PROJECT INTRODUCTION	6
3. WORK PACKAGE 1 – PROTOCOL FOR FULL-SCALE MEASUREMENTS	9
3.1.1.1. INTRODUCTION	9
3.1.1.2. RESEARCH QUESTIONS.....	9
3.1.1.3. RESEARCH INTERVENTION	10
3.1.2. <i>Spatial light distribution typologies</i>	10
3.1.3. <i>Luminaire types</i>	10
3.1.4. <i>Classrooms</i>	12
3.1.5. <i>Research subjects</i>	14
3.1.5.1. RESEARCH METHOD.....	15
3.1.5.2. RESEARCH PROTOCOL	16
3.1.6. <i>Two scenarios</i>	16
3.1.7. <i>Two studies</i>	18
3.1.8. <i>Timeline</i>	19
3.1.9. <i>Data collection</i>	21
3.1.9.1. CONTINUOUS DATA COLLECTION.....	21
3.1.9.2. INDOOR CLIMATE	21
3.1.9.3. ENERGY CONSUMPTION	23
3.1.9.4. SET-TIME DATA COLLECTION.....	23
3.1.9.4.1. CLASSROOM DESIGN AND FURNITURE	23
3.1.9.4.2. SUBJECT DEMOGRAPHICS.....	23
3.1.9.4.3. INDOOR CLIMATE: LIGHTING.....	23
3.1.9.4.4. LEARNING	25
3.1.9.5. PARTNER COLLABORATION	34
3.1.10. <i>References</i>	35
4. WORK PACKAGE 2 – NEW LIGHTING AT FREDERIKSBERG SCHOOL	37
4.1.1.1. PRE-RESEARCH SITUATION	37
4.1.1.2. DURING INSTALLATION.....	37
5. WORK PACKAGE 3 – PILOT TEST	39
6. WORK PACKAGE 4 – FULL-SCALE TEST, GATHERING OF PHYSICAL DATA	40
6.1.1.1. INTRODUCTION	40
6.1.1.2. INDOOR DAYLIGHTING AND LIGHTING CONDITIONS.....	40
6.1.2. <i>Indoor lighting conditions</i>	40
6.1.3. <i>Indoor daylighting conditions</i>	48
6.1.4. <i>Conclusion</i>	51
6.1.4.1. OTHER INDOOR CLIMATE VARIABLES	52
6.1.5. <i>Conclusion</i>	56
6.1.5.1. ENERGY ANALYSIS	57

6.1.6.	Conclusion.....	63
6.1.6.1.	SOUND DATA.....	63
6.1.7.	Conclusion.....	67
6.1.8.	References.....	67
6.1.8.1.	RESULTS FROM PERFORMANCE TESTS.....	68
6.1.9.	Conclusion.....	71
7.	WORK PACKAGE 5 – FULL SCALE TEST, GATHERING OF QUALITATIVE DATA..	72
7.1.1.1.	INTRODUCTION.....	72
7.1.1.2.	CLASSROOM OBSERVATIONS.....	72
7.1.1.3.	INTERVIEWS.....	73
7.1.2.	Group interview.....	74
7.1.3.	Individual interviews.....	74
7.1.4.	Pupil interviews.....	75
7.1.5.	Follow-up interviews.....	75
7.1.5.1.	RESULTS.....	75
7.1.6.	Lighting application.....	75
7.1.7.	Behavioral effects.....	76
7.1.8.	Conclusion.....	79
7.1.8.1.	REFERENCES.....	81
8.	WORKPACKAGE 6 – OVERALL EVALUATION.....	82
8.1.	CONCLUSION.....	82
8.2.	KONKLUSION (DANSK).....	83
9.	WORK PACKAGE 7 – DISSEMINATION.....	85
10.	APPENDICES.....	87
	APPENDIX A1 TYPE A LUMINAIRE.....	87
	APPENDIX A2 TYPE B LUMINAIRE.....	87
	APPENDIX B LOCATION OF CLASSROOMS WITHIN BUILDING.....	89
	APPENDIX C DAYLIGHT SIMULATIONS INTO CLASSROOMS.....	90
	APPENDIX D LIGHTING MEASUREMENT GRID.....	92
	APPENDIX E WORK PACKAGE 4 – FULL-SCALE TEST, GATHERING OF PHYSICAL DATA.....	94
	ILLUMINANCE HAND-SPOT MEASUREMENTS.....	94

1. Resume (Dansk)

Det er projektets formål at påvise den grundlæggende hypotese, at der gennem belysningsmiljøer, hvor der arbejdes bevidst med differentieret lys, både kan spares på energiforbruget til den kunstige belysning og skabes ro og fokuseret læring. Dette opnås ved at lyset placeres tættere på området, der skal belyses så spildlys undgås samt kommer ned i øjenhøjde og afgrænser rum i kraft af lys, mørke og kontraster. Således opnås der ud over energibesparelse også større komfort og ro i klasselokalet.

Dette pilotstudie viser, at fordelingen af belysning i lokaler kan have en betydelig indvirkning på læringsmiljøet. Yderligere undersøgelser er nødvendige for at få fuldt ud at forstå indflydelse og mekanismer.

Hovedresultaterne fra projektet viser at:

1) Energibesparelse.

Der opnås energibesparelse ved at placere lyset tættere på det område der skal belyses. I dette tilfælde elevernes arbejdsborde. Vi kalder denne type belysning for fokuseret lys, og skabes typisk med pendler. Energibesparelsen er vurderet i forhold til det klassiske belysningsystem i en skoleklasse, hvor der belyses jævnt i hele klassen fra armaturer integreret i loftet. Energibesparelsen varierer afhængig af om belysningen kan dæmpes. I det scenarie hvor pendlere er på max output opnås energibesparelse på 32-38% i de 4 undersøgte lokaler. Ved yderligere at give brugerne mulighed for at dæmpe pendlere kan opnås energibesparelser på op til 68%.

2) Ro i lokalet

Støjniveauet blev målt under både den fokuserede belysning og den generelle loftsbelysning. Ved at sammenligne 20 ens-svarende undervisningssituationer med hensyn til aktivitetstype og antal studerende fandt vi, at støjniveauet for 70% af de målte tilfælde sænkes mellem 1-6dB, hvilket potentielt indebærer, at eleverne kan fokusere bedre. Af de 14 forbedrede forhold viser 11 tilfælde en hørbar forbedring på mellem 1 og 3 dB, og vi fandt 4 tilfælde med mere end 3 dB, hvilket betragtes som en betydelig forbedring. Den gennemsnitlige forbedring i støjniveauet var ikke stor, men klart over den perceptuelle mærkbare forskel.

3) Forbedret indlæring

Indlæring blev testet i form af matematik- og kreativitet test.

Analyser af matematiktests, viser at elevernes resultater forbedres mellem 2 og 25% under fokuserede belysningsforhold i forhold til den generelle belysning. Disse resultater indikerer at eleverne får bedre testresultater under den fokuserede belysning.

Analyserne af kreativitetstests viser at eleverne både er mere og mindre kreative under den fokuserede belysning. Resultaterne fra pilot-studiet viser, at det er vigtigt at give eleverne et lys, der kan tilpasses efter undervisningssituationen.

4) Lysfordeling

Ved alene brug af loftsbelysning opnåede alle klasseværelser de belysningsstyrker, der anbefales i lysstandarderne EN12464-1 og DS700. De fleste af rummene har en vandret belysning på 200lux eller derover (højest 450lux) i arbejdsplanet. Ensartetheden er 0,4 eller højere for 63% af målingerne og aldrig lavere end 0,3.

Når pendler er en del af scenariet, er ensartetheden under 0,2 for alle tilfælde, og belysningsniveauet mellem pendlerne viser 50-150lux afhængigt af om loftbelysningen er tændt eller slukket. Det betyder, at ensartetheden, der anbefales i de tidligere nævnte standarder, ikke er opfyldt. Med pendler tændt, har børnenes arbejdsområde en vandret belysning på 500lux eller mere.

Med pendler tændt observeres en variation i rummets lysfordeling, der skaber fokuserede lyse områder hvor børn arbejder og blødt lys mellem arbejdsområder. Med det mere jævnt fordelte lysscenario fra loftsbelysningen, er belysningsforholdene ret ensartede i hele lokalet, og der skabes ikke områder med fokus.

5) Kvalitative resultater

Derudover viste de kvalitative undersøgelser, at brugen af pendlerne kan give anledning til ændret adfærd hos eleverne. Der var specielt en adfærdsændring at se, når eleverne blev sat til at løse specifikke opgaver. Brugerne var så tilfredse med pendlerne, at de vil beholde dem som et permanent tiltag i deres undervisning. Dette er en positiv bekræftelse på, at den nye belysning har et positivt bidrag.

2.

Overview

The following chapters summarize the findings from the research conducted by the partners in the ELFORSK project 349-062 “Light at eye level is a means to create energy savings and space for learning, focus and concentration”.

The chapters are structured according to the seven work packages defined in the ELFORSK application.

Project partners:

HLA	Behavioral studies + Light mapping + Sound and Movement recording
Anne Iversen	AIV@henninglarsen.com
Imke Wies van Mil	IWM@henninglarsen.com
Aarhus University	Light, temperature, air quality data, energy, Academic tests
Werner Osterhaus	Werner.Osterhaus@eng.au.dk
Steffen Petersen	Steffen.Petersen@eng.au.dk
Maria Garcia Alvarez	
Sophie Stoffer	
DTU Acoustics	Sound recording
Cheol-Ho Jeong	chj@elektro.dtu.dk

2.1.1.1. Aim

This project aims to test the hypothesis that non-uniform distribution of light is a means to save energy and create an educational space that supports pupils’ ability to learn.

2.1.1.2. Project introduction

The new *Frederiksbjerg School* (an elementary school) in Aarhus was inaugurated in August 2016 and has been taken into use since. During the design process of this building, significant attention had been given to optimize the natural light conditions in its learning spaces. Both in order to achieve a sustainable building with low energy consumption, as well as to guarantee suitable indoor climate conditions catering for human comfort. However, no special attention went out towards the design of the electric lighting in the learning spaces as a means to optimize their indoor conditions more holistically. This is not unique to this project, but also applies to many other educational projects, both regarding newly constructed as well as renovation of existing buildings. Electric lighting for learning spaces is in principle designed according to Denmark’s building regulations (currently in line with the European Lighting Standard EN12464-1) and therefore generally complies with achieving an average of 300lux with a uniformity level of 0.6 across the entire working plane of a learning space. This design approach is considered to create a uniformly (or with little variation between light and dark) illuminated space and work surface that ensures for appropriate visibility for all users at every location in the room, when the lighting system is activated. Secondly, in a ‘best case’ design, the system is specified to be fitted with low-energy (LED) lighting technology, complemented by a control system for it to respond to daylight availability which both are considered to decrease the building’s energy consumption. Both are in place in the classrooms of *Frederiksbjerg School*: a ceiling-based lighting system with LED technology – that makes

for a uniform distribution of light across the classroom – with control technology that allows for daylight responsive dimming (with an option to manually override). With our research, we would like to challenge the conventional way of electrically illuminating learning spaces to be homogeneously illuminated during all hours of use and type of users and activities. And investigate whether alternative lighting designs, which step away from uniformity, could be more beneficial. Both from a human performance as well as energy savings perspective.

This ambition builds upon previous research that found that although uniformly illuminated spaces might optimize the conditions for visibility best, it is not always the most beneficial condition when looking at the impact of light on human functioning and comfort in a broader context, and herewith, our performance of the task at hand (Barrett, 2015; Boyce, 2014; Flynn, 1973, 1977, 1979; Gifford, 2007; Govén, 2009; Vogels, 2008; Wessolowski, 2014). What type of room illumination suits best depends greatly – amongst others – on the type of activities that are taking place and type of population present. Hence, flooding an entire room consistently with the same quantity and quality of light, always, might not always be beneficial from a performance perspective. And if this holds true, it might also unnecessarily consume energy.

With this knowledge in mind, we performed explorative field studies in several Danish typical school classrooms to investigate the current indoor (including lighting) conditions, and the experience of pupils and teachers have with these. We learned – amongst others – that they consider it relatively difficult to achieve an atmosphere in their classroom during those educational activities that require (greater) concentration and quietness. This inspired us to further investigate how lighting can play a more active role in creating a supportive atmosphere for concentration.

As it emerged from preceding research that non-uniform light distribution could support different tasks and behavior than uniform light distribution, we set out to test the following research hypothesis: *“Non-uniform lighting is beneficial to improve pupil’s ability to concentrate during certain learning activities, whilst at the same time lowering the overall energy consumption of the learning space”*.

In order to assess the impact of a non-uniform lighting scenario on pupil behavior, we equipped four test-classrooms at Frederiksbjerg School with the option to activate a **non-uniform** electric lighting scenario, as an additional option to the standard, **uniform** lighting scenario already present in these classrooms. We then assessed both qualitatively and quantitatively, how these two scenarios influenced pupil behavior. In addition, we assessed what the impact of an additional light scenario has on the classroom’s energy consumption. This took place during three consecutive months, February – April 2017, when the existing and new lighting installations in these four learning spaces have been used, or “experienced”, during normal curricular activities and by the same pupil and teacher groups. During this period, we have taken continuous, physical measurements of energy consumption, daylight and electric light levels, and taken measurements of the air quality (CO₂ and humidity) and thermal indoor climate. Furthermore, we investigated the impact of non-uniform versus uniform electric lighting on pupil behavior (and in particular their ability to concentrate) through in-classroom observations, teacher and pupil interviews, as well as by recording in-classroom sound levels accompanied by analyzing in-classroom video recordings.

The results from our analysis of these data collections provide for initial evidence that conscious design of electric lighting resulting in allowing for non-uniform lighting conditions (in our research in the form of local illuminated zones of light at eye level) can create both energy savings as well as comfortable areas for concentration and calmness in the modern, larger learning space which nowadays hosts many pupils and diverse activities.

3. Work package 1 – Protocol for full-scale measurements

3.1.1.1. Introduction

Work package 1 summarizes our research ambition, protocol and approach to collaborations between the different research partners. The research protocol has been prepared amongst the collaborators in 2016 and has been executed during 2017 by means of several research-interventions in four formal learning spaces at *Frederiksbjerg School*. The aim of these interventions has been to study the relationship between how electric light is distributed in a learning space (or in other words: to what extent it creates for a uniform versus non-uniform distribution of light) and pupil behavior (as defined by five typical measures – see next page), and how it might affect the overall energy consumption of a typical classroom.

3.1.1.2. Research questions

- Does the environmental parameter spatial light distribution influence pupils' ability to learn in a standard classroom setting at *Frederiksbjerg School*?
- Does an electric lighting system that allows to vary spatial light distribution influence the overall energy consumption of this classroom relative to the standard system?

Spatial light distribution is our independent research variable and refers to how light is spread throughout a space, or what pattern of “light and darkness” it creates (Boyce, 2014). The extreme situations are (a) a very uniform (or homogeneous) distribution of light, where there is little variation throughout an entire space; and (b) a very non-uniform (or dramatic) distribution of light, with great variation of light and dark. In this research, we focus specifically on how electric light influences spatial light distribution in a standard classroom by manipulating the electric lighting system producing it. It should be noted though, that the classrooms included in this research all have windows with automatic, external semi-transparent shading. The presence and penetration of natural light into these rooms and its subsequent influence on spatial light distribution is considered one of our intervening research variables.

Learning is our dependent research variable and generally defined as: “... *the acquisition of knowledge or skills by a pupil through study, experience, or being taught*”. The ‘pupil’ refers to the “*person that is learning*”. Previous research uncovered various parameters that influence how well a pupil is able to learn. One of such parameters is the physical environment where the learning takes place (Gifford, 2007; Barrett, 2015). Light – both natural and electric – is one of such environmental parameters (Boyce, 2014); and spatial light distribution one of its characteristics influencing us humans (Flynn, 1973, 1977, 1979). To enable us to study the potential impact (suggesting a change for better or worse) of spatial light distribution (co-)created by the electric lighting installation on the pupils’ ability to learn, we have selected five behavioral factors.

These stem from previous research done with similar aims (Barrett, 2015), and that were found to be measurable:

1. Engagement: levels of attention, concentration, on-task behavior, and off-task (distracted or disruptive) behavior of pupils;
2. Communication: social behavior between teacher and pupils, and amongst pupils;
3. Affect: mood of and motivation in pupils;
4. Visual comfort: visual (dis)comfort of pupils;
5. Attainment: academic performance (measured by standardized tests)

We have studied (or “measured”) these factors through a mixed method approach, thus by using quantitative and qualitative methods.

3.1.1.3. Research intervention

In order to answer the above stated research questions, we performed so called field experiments (or interventions), during which we studied the potential influence of **two** distinctively different spatial light distribution typologies on pupils’ ability to learn (according to five measurable parameters). We performed our experiment in **four** typical classrooms at *Frederiksbjerg School* and included **ten** groups of pupils (ca. 20-25 per group) and **six** teachers.

3.1.2. Spatial light distribution typologies

The two types of spatial light distribution that we studied are:



- **Type A: uniform spatial light distribution**

A room with uniform spatial light distribution is considered to have a rather uniformly illuminated appearance – with little contrast between light and dark. Figure 3.1 presents an example of uniform spatial light distribution. In our research, this is currently present in all four classrooms and is created by regularly placed, illuminating ceiling tiles;



- **Type B: non-uniform spatial light distribution**

A room with non-uniform spatial light distribution is considered to display great(er) contrasts; or significant variations between light and darker areas. Often light is bundled or concentrated at localities, while other areas are not directly illuminated. Figure 3.2 presents an example of non-uniform spatial light distribution. The option to create non-uniform spatial light distribution has been added to our four classrooms by means of pendants.



Figure 3.1: Type A uniform spatial light distribution

Figure 3.2: Type B non-uniform spatial light distribution

3.1.3. Luminaire types

There are two types of luminaires included into our studies:

Default luminaire

The existing, default luminaire is a ceiling recessed LED panel with diffuse light intensity distribution (Appendix A1):

Product: LedUsed III (by Solar Lighting)
Dimension: 600x600mm
CCT: 4000K
Output/W: 4300lm/45W (96 lm/W)
Control: Manual switch: On/Off, (daylight) dimmable



Positioning

In each field study classroom there are six LedUsed III luminaires positioned in a regular grid. A manual switch for on/off and dimming is positioned onto the wall near the classroom entrance door, and a second one near the classroom's smart board.

Output

DIALux calculations indicate that the average illuminance achieved by these six luminaires on the horizontal working plane (+0.6m) excluding daylight contributions, at full power is about 450lux with a uniformity across the working plane of circa 0.45. It should be noted though, that in practice each classrooms' control system is set to adjust the actual output of the luminaires to keep a constant 300lux on the working plane. It does so by help of a light sensor centrally placed on the ceiling of each classroom, that monitors (day)light levels continually, and adjusts the luminaires' output accordingly. Based on our estimations, the light level and uniformity in the classroom is in line with the recommended values of lighting standards EN12464-1 and DS700, which respectively suggest 300lux and 200lux, and a uniformity across the working plane of circa 0.40.

Pendant luminaire

The newly added "focused" luminaire is a LED pendant with downward, bundled light intensity distribution (Appendix A2):

Product: Dino Classic (by Fagerhult)
Dimension: Diameter: 300mm
CCT: 4000K
Output/W: 1325lm/16W (83 lm/W)
Control: Manual switch: On/Off (non-dimmable)



Positioning

In each of our classrooms, six Dino Classic luminaires are added. They are aligned with the furniture layout, but not colliding with the existing default lighting and other ceiling installations. These pendants are suspended from the ceiling to circa +1.8m above floor level to avoid that pupils physically interact with the luminaires, as well as to avoid interferences with the teacher's and learner's line of sight. In each classroom, the pendants are wired together in an independent circuit, so that they can be switched on or off as a group by the teacher via a separate manual switch placed next to the standard light switch at the entrance door.

Output

DIALux calculations indicate that at the horizontal working plane (+0.6m) the average illuminance will be circa 270lux excluding daylight contributions, with a uniformity of maximum 0.1, which is expected when applying a non-uniform lighting solution. The predicted minimum and maximum values will be ranging between 100lux in between pendants, and 1000lux just directly below a pendant – both at working height. The

predicted average light level at table areas where pupils will be working is around 500lux. This is about a meter radius from the center of a pendant.

3.1.4. Classrooms

The field studies are executed in two pairs (Fig. 3.3) of standard classrooms located at level 1 and 2 in the northern part of the building block (Appendix B).

- One pair of classrooms 1A (01.1.05) and 1B (01.1.10) are located side-by-side at level 1. Each classroom is used by one *Indskoling* group; each group spends their entire day (excl lunch, outdoor time) in their respective room with the same teacher.
- The second pair of classrooms 2A (02.1.06) and 2B (02.1.10) are located side-by-side directly above, at level 2. These classrooms are used by *Mellemtrin* pupils studying Mathematics and are used by several groups during the day.



Figure 3.3: Locations of the four classrooms included into our studies

Classroom layout

The classrooms have a comparable layout that includes three distinct “areas” (Fig 3.4):

- General area: for small-group and individual work with tables and seating,
- Instruction area: for groups instruction and smartboard use with a podium,
- Special area: for special tutoring to selected learners) with tables and seating. This area is separated by the other two areas by a glass wall.



Figure 3.4: The general area of classroom 1A (01.1.05)

In this research we will focus solely on studying the effect of electric light distribution in the general area, which has the following relevant characteristics:

- Floor to ceiling height of each room is +3.0m; depth of each room 9.16m;
- Floor, wall and ceiling finishes are comparable: blue linoleum floors, white acoustic, suspended ceiling panels (0.60m*0.60m or 1.20m*0.60m) and white and brightly colored walls;
- Furniture consists of wooden shelving along some of the walls, movable grey colored tables, and black chairs. For each classroom, there is a standard furniture and seating layout, but for certain activities, tables and chairs may be moved.

Natural light

All four classrooms have daylight (and occasionally sunlight) entering the spaces through east-facing windows of two sizes: small and large, that are positioned either near the floor, in the middle of the wall, or towards the ceiling. The arrangement of windows differs along the façade, and thus per classroom. The total window surface per room is, however, fairly similar (Fig. 3.5).

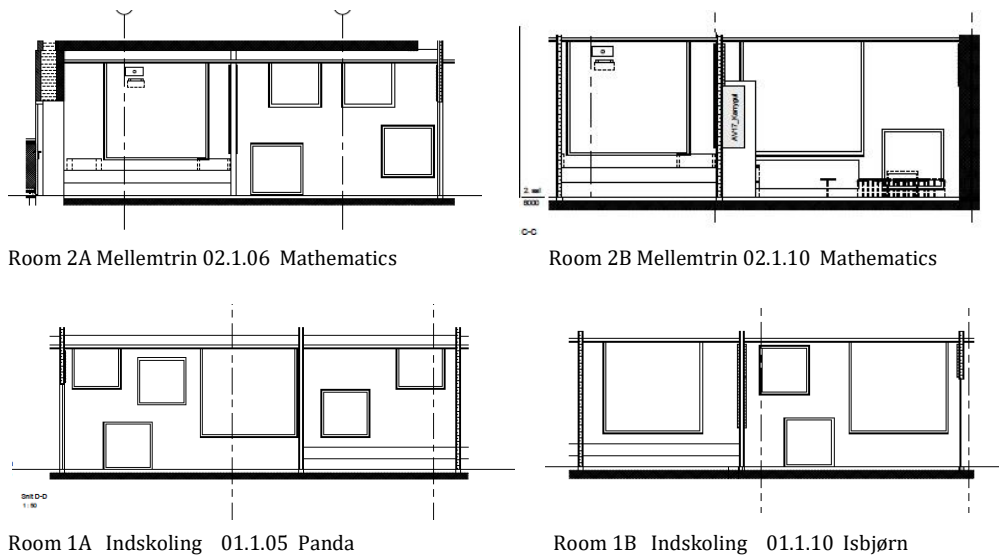

Figure 3.5: Window arrangement per classroom

All windows are equipped with external shading automatically deployed/retracted by signals from daylight sensors externally positioned along the façade. Opposite to this building façade, there are equally tall building blocks that obstruct most direct sunlight to reach our façade. As the windows are facing the same direction and obstruction, the behavior of daylight in these rooms is relatively similar on both levels. See Appendix C for further details on daylight predictions.

3.1.5. Research subjects

We have included two pupil age groups into our research: pupils at *indskoling* (entry) level (circa 6-9 years old) and pupils at *melletrin* (medium) level (circa 9-12 years old). We have chosen to study the effect of spatial light distribution on pupils of these age groups because first of all, results from previous research in the field of “light and learning” suggest that most profound effects of light on pupil learning manifests itself most evidently and relatively quick for pre-adolescent pupils (Barrett, 2015). Due to the limited time given by Frederiksbjerg School to execute our research in-house, we therefore excluded *udskoling* (upper) level pupils from our subject pool (as these enter the age of adolescence).

And secondly, it allows us to study potential effects on pupil populations that spend their entire day in one classroom (*indskoling*), as well as potential effects on pupil populations that move around in groups during the day from classroom to classroom (*melletrin*). At *melletrin* level, most classrooms are dedicated to a particular curriculum. For the classrooms in our study, the subject taught was Mathematics. Both situations – fixed classroom use and circulating between different classrooms – are common situations in most (Danish) elementary schools today. By including both into our research, it allows us to discuss potential effects in both situations separately.

Pupil groups

During our research, we studied ten groups of pupils which did not have any changes in the pupil group, e.g. school leavers, but a few absences due to illness were recorded during our study. Of this ten, two groups studied were at *indskoling* level: Panda and Isbjørn, who each spend the majority of their time in their own respective classroom. And

eight groups at *mellemtrin* level, that rotate their presence in the two mathematics classrooms. Included in our study were also six teachers: two indskoling teachers (one for each group) and four mathematic teachers, who rotate between the classrooms.

Typical classroom schedule

A typical “school day” at both levels can be approximated by the following schedule of learning “sessions” and breaks between 08:00 (start of day) and 14:00 (end of day):

- 08:00 – 08:45 session 1A and 08:45 – 09:30 session 1B
- 09:30 – 10:00 break 1
- 10:00 – 10:45 session 2A and 10:45 – 11:30 session 2B
- 11.30 – 12:30 break 2 (including lunch)
- 12:30 – 13:15 session 3A and 13:15 – 14:00 session 3B

At *mellemtrin*, this means that during one day, up to six different groups may use one classroom. However, most often one group plus their teacher stayed in a mathematics classroom for a complete session of 90 minutes.

3.1.5.1. Research Method

To investigate if our independent research variable – *spatial light distribution* – influences learning behavior in and the energy consumption of a classroom, we performed field experiments. **Field experimentation** as a method of research enabled us to examine the impact of an intervention, in our case the addition of pendants to create a non-uniform spatial light distribution, on pupils and teachers in their naturally occurring learning environments, rather than in a laboratory setting (Groat, 2013).

To collect data on our dependent research variables (the five measurable behavioral factors related to “learning” and the energy consumption of each classroom) we applied a mixed method approach and included both quantitative – such as light measurements, energy consumption logging and audio recording – as well as qualitative research techniques – such as semi-structured interviews and classroom observations. We also collected data on a range of (potentially) intervening variables as we cannot control everything in the “field” and there is possibility of contamination. The overview below summarizes our research variables and respective data collection techniques.

Research variable

Data collection technique

Independent Variable

- | | |
|--|--|
| <ul style="list-style-type: none"> • Spatial light distribution | <ul style="list-style-type: none"> • 3D Luminance mapping (HDRI) • Luminance measurements (handheld meter) • Illuminance measurements (handheld lux meter) • Continuous illuminance recording (HOB0, Li-Cor) |
|--|--|

Dependent Variables

Behavioral factors (learning)

- | | |
|---|--|
| <ul style="list-style-type: none"> • Engagement (i.e. concentration) • Social behavior • Affect (mood, motivation) • Well-being (visual comfort) • Attainment (<i>Mellemtrin only</i>) | <ul style="list-style-type: none"> • Classroom observations + teacher interviews + audio recording + movement mapping • Teacher and pupil interviews + luminance measurements and mapping (HDRI) • Academic (math + creativity) tests |
|---|--|

Energy measures

- Energy consumption
- Energy monitoring by Tridonic control system

Potential intervening variables

Other indoor environment conditions

- Daylight presence (blinds)
- Daylight levels
- Temperature
- Air quality (CO₂)
- Humidity
- Weather conditions
- Building management system open/closed
- Outdoor and indoor light sensors (Li-Cor + HOBO)
- Automatic temp loggers (Tinytag)
- Automatic CO₂ loggers (Tinytag)
- Automatic humidity loggers
- As recorded by observant on the day + online data

Classroom

- Architectural room design
- Interior and furniture layout
- Architectural documentation + Field visits (to evaluate “comparability” of the four classrooms)

Subjects

- Group demographics
- Learning (dis)abilities
- Typical” groups’ behavior
- List of pupils per group
- Teacher information
- Teacher information

Activities

- Teaching style (per teacher)
- Curriculum (type of lesson)
- Teacher information + Pilot study observation
- Teacher information + Classroom schedules

Interruptions

- Presence of observer
- Significant external influences
- Abnormal interruptions
- Absentees
- Observation notes
- Observation notes
- Observation notes + teacher interview
- List of attendees from teacher

Timing

- Time of day / week / year
- Observation notes

Some data collection took place continuously throughout our both our studies, others took place at set moments in time. In the next chapter, an overview of our research protocol and the timing of data collection activities is described.

3.1.5.2. Research Protocol

Our field experiment set-up and data collection protocol allowed us to study two types of light distribution scenarios during two consecutive studies.

3.1.6. Two scenarios

Prior to doing any studies, we equipped all four classrooms with the new pendant luminaires and accompanying control equipment in addition to the existing ceiling lighting. This allowed us to activate one of the two scenarios in a classroom and easily swap – whilst keeping a similar appearance of each classroom during the entire study period.

Default scenario (uniform spatial light distribution)

In the existing, default scenario (Fig.3.7) the teacher (and pupils) can choose to activate the ceiling lighting and create a uniform light distribution in their classroom. By default, the control system will ensure that approximately 300lux is available at working height, continuously. If desired by the users, they may override the system and decrease or increase the light level according to their needs. This does not significantly change the appearance of the light distribution in the classroom but will change illuminance and luminance values.

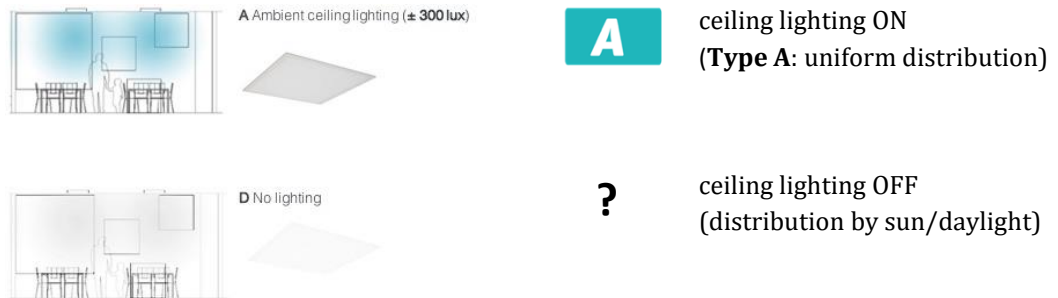

Figure 3.6: Default scenario (uniform spatial light distribution)

NOTE: in this scenario the pendants are physically de-activated and positioned close to the ceiling to avoid interference as much as possible.

New scenario (e.a. non-uniform spatial light distribution)

In the new scenario (Fig. 3.7), the pendants are suspended above the working tables just above eye height. The teacher (and pupils) can choose to activate them, which will achieve about 500lux at a working surface underneath a pendant and generate a non-uniform spatial light distribution in the classroom (type B1). It is also possible to activate the pendants and default ceiling lighting together (type B2). In this situation, there is still a case of non-uniform distribution, but the differences between light and dark areas are less pronounced. Thirdly, as we are doing our studies in a real environment, it remains also possible to only activate the ceiling lighting (and no pendants) if this is deemed to be the best solution by the classroom users at that moment in time. We are studying if the non-uniform spatial light distribution (type B) has an influence, but at the same time need it to be meaningful to the pupils and teachers, and not to be an enforced scenario. However, for ease of discussion, we consider the new scenario to create a non-uniform distribution (type B).

NOTE: If the ceiling lighting is activated in this scenario, the control system will stabilize its output to approximately 200lux at working height. We chose to lower the target illuminance from 300lux to 200 lux as this is sufficient to support general activities. When pendants are also activated (achieving 500lux at the desks), the ceiling lighting acts more as a background illumination and does not override the non-uniform distribution of light created by the pendants. If desired, the output of the ceiling luminaires can still be manually de- or increased as in the default scenario.

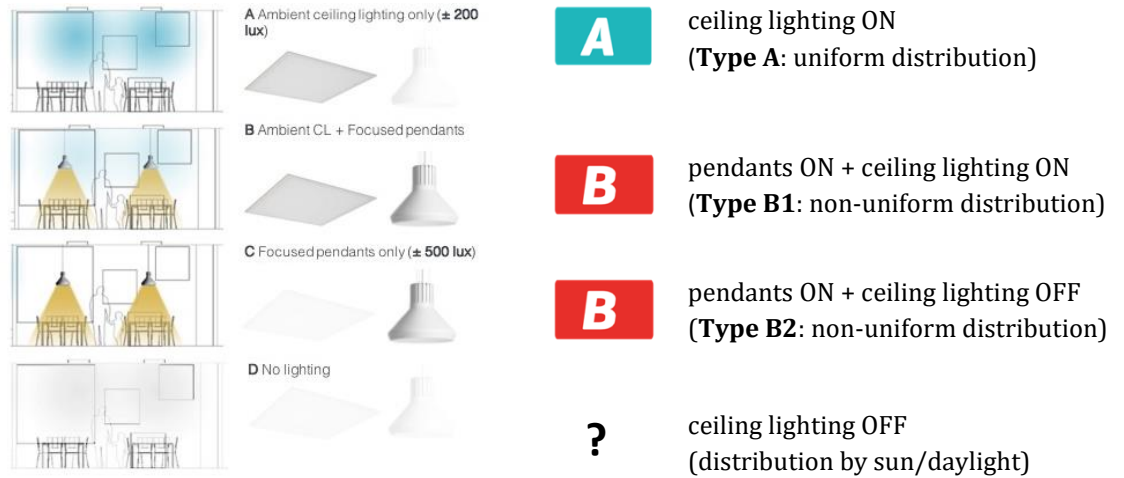
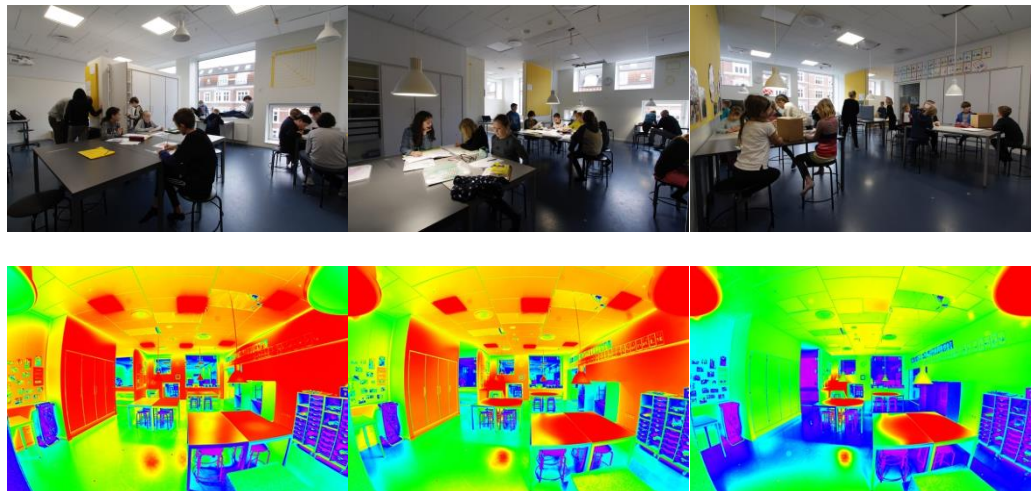

Figure 3.7: New scenario (non-uniform spatial light distribution)

Figure 2.8 shows some example situations of typical forms of spatial light distribution as present during our studies. Underneath are corresponding false color plots indicating brighter (yellow-red) or darker areas (blue-green).



Type A: uniform distribution Type B1: non-uniform distribution Type B2: non-uniform distribution

Figure 3.8: Examples of possible spatial light distribution options

3.1.7. Two studies

We completed two consecutive research studies (**STUDY 1** and **STUDY 2**) of three weeks each (or 15 educational days) during which we collected data following the same protocol both times. During both studies, we alternated the activation of the two spatial light distribution scenarios as following (Fig 2.9):

- During **STUDY 1**, classrooms 1A + 2A used the **default** spatial light distribution scenario, and classrooms 1B + 2B used the **new** scenario;
- During **STUDY 2**, classrooms 1A + 2A used the **new** spatial light distribution scenario, and classrooms 1B + 2B used the **default** lighting system;

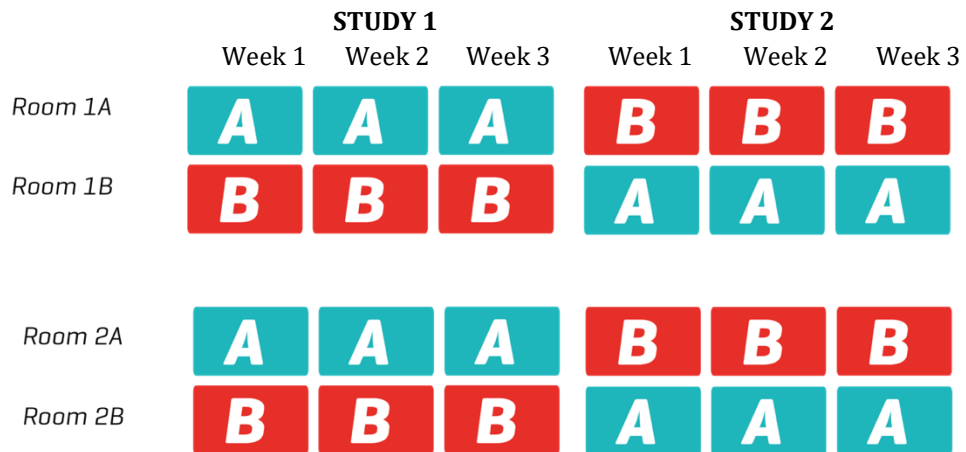

Figure 3.9: Study schedule

By alternating the two scenarios for each classroom-pair per study, we attempted to exclude potential differences in natural light presence – i.e. due to weather changes and timing influences such as the lengthening of daylight hours and the increase of average daylight levels – during our research studies as an intervening variable. Secondly, we wanted to investigate whether the order in which pupils were exposed to the different lighting scenarios would make a difference. During the study period, pupils and teachers were engaged in their regular activities and were exposed to one of the two lighting scenarios. The first 10 days of each study period were intended for the teachers and pupils to become familiar and adjusted to the new lighting situation. In the third week, specific data collection activities took place on Wednesday and Thursdays on “learning”.

3.1.8. Timeline

Our field experiment timeline ran throughout 2017 and consisted out of seven parts:

1. preparation (week 03)
2. pilot study (week 05)
3. temporary installation of new lighting, controls and sensors (week 7, *Christmas holidays*)
4. study 1 (week 8-11)
5. study 2 (week 11-14)
6. removal of sensors (week 15, *Easter holidays*) (*pendants were fixed permanently*)
7. Performance tests and follow-up interviews (week 45-48)

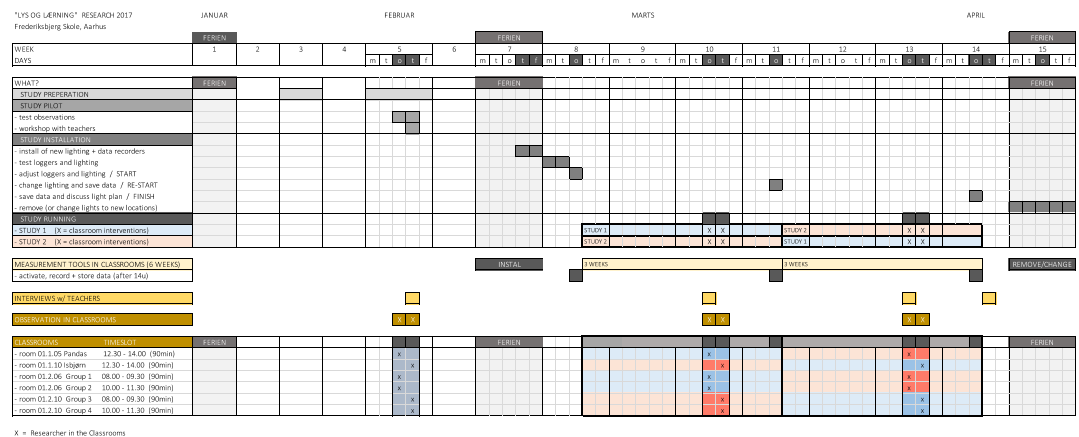

The scheduling and accompanying activities of each part are described below:

Preparation activities (week 03)

Before our field experiments commenced, the following activities took place during the weeks leading up to it, and specifically in **week 03** (18-19 January):

- Agreement on furniture layout for each classroom, that will remain as much as possible in place throughout our research period;
- Description and photographing of architectural and designed context of each room (classroom layout, interior design, furniture positioning, added “personalizing” objects such as posters etc.);
- Introduction of the research to the teachers and pupils included in the studies;
- Group interviews (circa 45 min) with the six selected teachers to collect current thoughts about and experiences with the (electric) lighting in their respective classroom;
- Basic demographic survey of each pupil group to map their “make-up” (age, gender, disabilities, etc);

Pilot study (week 05)

- In this week, we ran our prepared data collection protocol, specifically our observation protocol for the two Wednesdays and Thursdays. This experience helped us to refine the protocol further. It also gave the pupils and teachers some time to get “used” to having an observer in their classroom (hence, trying to remove the “observer-presence effect” possibly contaminating otherwise study 1 and 2;
- We evaluated the educational context in each of the four classrooms by analyzing each teacher/teaching style, as well as the default “group-dynamics” (e.g. general ambience or attitude of a particular group) intended to be included in our actual studies. This allowed us to define whether the studied classrooms and their respective pupil groups and teachers are comparable to each other in their typical “behaviors”.

Installation (week 07)

- Installation of DALI control monitoring system in each classroom (inside the ceiling);
- Installation of 4 x 6 new pendants **Type B** into all four classrooms, a local control switch on the wall, and an independent control circuit connected to the DALI system to enable continuous activation and dimming state logging;
- Check of the 4 x 6 existing luminaire **Type A** drivers in the four classrooms to make sure they are all on the same setting to achieve 300lux average illuminance at the working plane (+0.6m). And connection of each group of 6 to the DALI hub and laptop to enable continuous activation and dimming state logging;
- Set-up of automatic indoor environment sensors (light, temperature, CO₂ and humidity recorders) in each classroom to record continuously throughout the entire study period.

Studies 1 and 2 (week 08-14)

The following data collection activities took place during study 1 and 2 in all classrooms:

- Continuous data collection: all sensors and energy monitor systems were pre-set to activate on Monday 20 February at 06:00, and finish logging on 5 April at 20:00.
- Set-time data collection: the intervention sessions took place on Wednesday March 8th and Thursday March 9th (study 1) and Wednesday March 29th and Thursday March 30th (study 2). One researcher (always the same person) worked according to the following schedule:

<i>Time</i>	<i>Activity</i>
07:00 – 08:00	prepared all four rooms with setting-up and activating time-lapse video equipment and sound recorders
08:00 – 09:30	Observe* and video record session 1
10:00 – 11:30	Observe* and video record session 2
11:30 – 12:30	Checking on status of 4 video and sound recorders Possibly doing interview with teacher (when agreed)
12:30 – 14:00	Observe* and video record session 3
14:00 – 16:00	Deactivate time-lapse video equipment and sound recorders Taking light level measurements (daytime) all four classrooms Taking HDRI photos (daytime) in all four classrooms Possibly doing interview with teacher (when agreed)
18:00 – 22:00	Take light level measurements (daytime) all four classrooms Take HDRI photos (daytime) in all four classrooms

Removal (week 15)

- Removal of automatic data collection tools for processing and analysis
- Permanent installation of pendants in the four classrooms

NOTE: The school requested that the pendants stay in place as they were found to benefit the pupils. Thus, instead of removing and ensuring each classroom to go back to its original state, the pendants were installed permanently.

Performance tests and follow up interviews (week 45 – 48)

- Re-interview teachers after six months+ experience with the new lighting
- Execute two type of performance test with *mellemtrin* students

3.1.9. Data collection

Our data collection took place during weeks 08 -14 and 45 -48 as described below. Some forms of data collections took place continuously throughout these weeks, others took place at set moments in time. Following an overview of all our data collection activities.

3.1.9.1. Continuous data collection

There were two forms of continuous data collection throughout the entire study period: indoor climate recording and energy consumption logging.

3.1.9.2. Indoor climate

In each classroom two temperature and humidity recorders (Tinytag), one CO₂ recorder and two illuminance (lux) sensors (HOBO, plus in one classroom also 2 Li-Cor sensors (Fig. 3.10). All have continuously logged data throughout our six-week study period.



Figure 3.10: Indoor climate data recorders

The Tinytag and CO₂ recorders were positioned directly underneath the ceiling, strategically away from air vents and ceiling luminaires. One of the HOBO light meters was placed centrally in the room, just dropped down below the ceiling. This sensor was positioned to measure illuminance levels on a vertical plane approximately at the middle of the room, with the sensor facing towards the windows to include daylight contributions. The second sensor was placed in a window frame measuring illuminance levels on a horizontal plane, facing upwards, to measure daylight levels reaching the interior at the façade. In one of the rooms, additional Li-Cor sensors were placed right beside each HOBO sensor. This was done because the HOBO sensor measures illuminance at a greater range of wavelengths than visible to the human eye. As we are interested in understanding the illuminance levels throughout our research period as humans perceive it, we used one pair of (more expensive) Li-Cor sensors (which measure light according to the human observer curve of the CIE) to calibrate our data collected by all our HOBO sensors (Fig. 3.11).



Figure 3.11: Location of sensors in Room 1B (01.1.10) marked with red rings

A third Li-Cor sensor was placed on top of the school's roof to log daylight levels from the unobstructed sky to give insight on the exterior daylight/sunlight availability throughout our study period.

NOTE: due to technical issues with the Li-Cor, this external data had to be discarded.

3.1.9.3. Energy consumption

In the ceiling of the general area in each classroom, six default ceiling luminaires, six pendants and one centrally located light sensor were present. The ceiling luminaires were wired to form 3 groups to allow for controlled dimming through the centrally located light sensor: one pair close the window façade, one pair around the center of the room and one pair near the back of the room. This was done to continuously achieve 300 lux at working height throughout the entire general area; both near the windows (with greater daylight contribution) and towards the back of the room (with least daylight contribution). The settings of all three groups were continuously logged. The six new pendants were grouped together as one, without connection to the light sensor. These would only activate at 100% or be off. The logging took place via a DALI bus connected with all twelve luminaires and the sensor, and a laptop with logging software by Tridonic masterCONFIGURATOR_V2.24.1.35.exe (Fig. 3.12).



Figure 3.12: Energy monitoring setup

3.1.9.4. Set-time data collection

Various forms of data collection took place during set moments throughout our studies:

3.1.9.4.1. Classroom design and furniture

Prior to our study, we evaluated architectural documentation for the school to select classrooms that physically would be similar in geometry, layout and window orientation and design. Following, we performed field studies (week 3, 2017) in those classrooms selected from the documentation to evaluate furniture layouts and room usage. From these studies, we selected the four classrooms that would be most comparable based on these parameters.

3.1.9.4.2. Subject demographics

After our field studies we received the time schedules for our selected four classrooms, and from these, we selected the pupil groups and teachers to be included in our study. After gaining consent to participate, we organized a teacher group interview to explain our research aims, discuss their teaching styles, and their present experience with the indoor climate, and particularly the lighting, of the included classrooms. From the school administration, we received lists of the names and gender of pupils per group. Special issues, such as learning disabilities etc., were discussed with the teachers.

3.1.9.4.3. Indoor climate: lighting

In addition to the continuous monitoring of general lighting throughout the entire research period, we also took specific lighting measurements (Illuminance at work plane and luminance distribution from two view points) in each of the four classrooms during study 1 and again during study 2. We took these measurements both during daytime

(with an overcast sky to avoid direct sunlight interference) as well as nighttime (to exclude any daylight). We measured illuminance (lux) levels with a handheld Konica-Minolta CL-200 chroma and illuminance meter at a 1m x 1m grid approx. 0.6m above the floor (Fig. 3.13 and Fig. 3.14) for each of the following settings:



Type A: uniform spatial light distribution

Daytime (overcast sky)

Evening time

- Daylight only
- Daylight + ceiling panels
- Ceiling panels



Type B: non-uniform spatial light distribution

Daytime (overcast sky)

Evening time

- Daylight only
- Daylight + pendants
- Daylight + pendants + panels
- Ceiling panels
- Ceiling panels + pendants

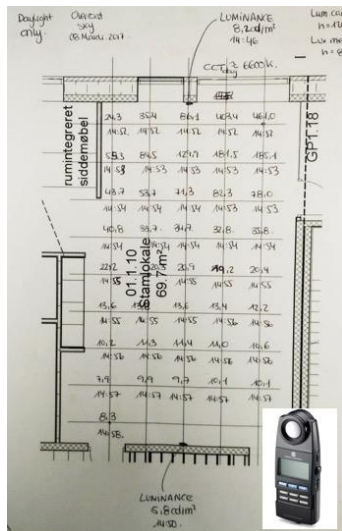
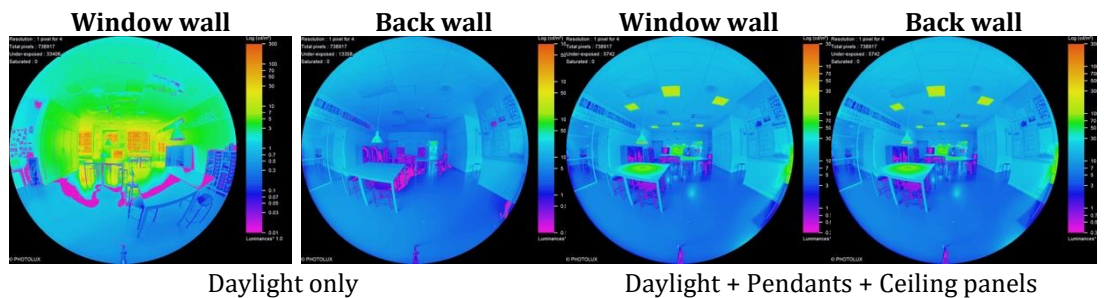

Figure 3.13: Example measurements



Figure 3.14: Hand measuring in action

In addition to these illuminance measurements along the horizontal plane, we also took high dynamic range images (HDRIs) of each setting and classroom to document the spatial distribution of luminance values across the room. A series of several images was combined into an HDRI image with the Photolux 3.2 software to produce a calibrated luminance map. We took photos in two directions per setting and classroom: towards the window façade and towards the back wall (Fig. 3.15).



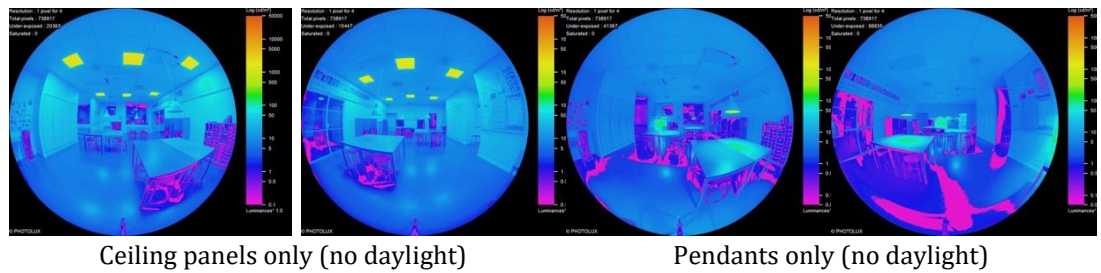

Figure 3.15 Examples of HDR calibrated luminance maps

To calibrate our images, we also measured luminance values with a hand-held luminance meter at fixed points on both walls. These luminance measurements were taken from the same position as the HDRIs, i.e. from the center of the rear wall or the center of the window wall in each room.

3.1.9.4.4. Learning

We used four data collection techniques to measure and assess a (potential) change in the five behavioral “learning” agencies (see paragraph 2.1):

- classroom observations,
- sound logging,
- teacher and pupil interviews,
- educational exercises

The learning data were collected in our four classrooms during one Wednesday and one Thursday per study. The respective time schedules per classroom for these days gave us three sessions of 90 minutes (or 2 x 45-min. sessions but these were most often combined in one 90-min. session per group) with the following pupil groups present:

WEDNESDAY	Indskoling		Mellemtrin (<i>matematik</i>)	
	Classroom 1A	Classroom 1B	Classroom 2A	Classroom 2B
Session 1 08:00 – 09:30	Panda	Isbjørn	Delta	Neptun
	Panda	Isbjørn	Delta	Neptun
Session 2 10:00 – 11:30	Panda	Isbjørn	Charlie	Stjernes kud
	Panda	Isbjørn	Charlie	Stjernes kud
Session 3 12:30 – 14:00	Panda	Isbjørn	Merkur	Regnbuerne
	Panda	Isbjørn	-	-

THURSDAY	Indskoling		Mellemtrin (<i>matematik</i>)	
	Classroom 1A	Classroom 1B	Classroom 2A	Classroom 2B
Session 1 08:00 – 09:30	Panda	Isbjørn	-	Nordlys
	Panda	Isbjørn	Merkur	Nordlys
Session 2 10:00 – 11:30	Panda	Isbjørn	Bravo	Jupiter
	Panda	Isbjørn	Bravo	Jupiter
Session 3 12:30 – 14:00	Panda	Isbjørn	Bravo	Charlie
	Panda	Isbjørn	-	-

In total we could include 48 sessions (4 days x 3 sessions x 4 classrooms) with nine (9) pupil groups at mellemtrin level and two (2) pupil groups at indskoling level. At mellemtrin level, all sessions were dedicated to *Mathematics*. For indskoling the sessions

were planned as following: session 1: *Mathematics*; session 2: *Danish*; and session 3: *English and Study Time*. Three out of four of our “techniques” took place continuously and simultaneously between 08:00 and 14:00 in all four classrooms (thus in all 48 sessions). One technique – observation in person – took place in 1 out of 4 classrooms per session, thus accumulating 12 sessions in total. We wanted to have the same researcher observing sessions / groups to ensure consistent data interpretation, and for her to observe them under exposure during both scenarios, the default lighting scenario and the new lighting scenario. The groups included in these sessions are highlighted above: Panda and Isbjørn at indskoling, and Delta, Charlie, Nordlys and Jupiter at mellemtrin.

Further explanation of the four research techniques we used to assess a potential change in “learning” due to differences in spatial light distribution in the classroom follows.

- ***Non-participant observation***

Observational research is a way of collecting data by observing naturally occurring events, situations, settings, behaviors, and other social phenomena as they occur, and taking notes of these (Wertz, 2013). Also observing and describing the context in which the behavior takes place, provides the possibility to look at the dynamic relationship between context and behavior.

All our observation sessions were completed by the same researcher, so that notes from different sessions would be comparable. She performed a form of non-participant observation, in which the observer does not interfere with or manipulate the event being observed, but to just observe as an outsider. Our subjects (pupils and teachers) were, however, aware that they were being observed. In this case, there is a risk that they become too conscious of their actions and do not behave and/or decide as they normally would, but rather in accordance with the observer’s expectations. In an attempt to avoid such data contamination as much as possible, our observer performed a pilot study a few weeks prior to our actual studies, during which she was present during all our planned sessions so that the “novelty” of having her present already would have worn off by the time the actual studies would take place. In addition, doing these “mock” sessions, our observer could test and improve her template and observation technique. This approach turned out to work quite well, as during these first visits, pupils often came over to ask questions and interact with our researcher, whereas in our second and third round of observation sessions, they hardly approached her and seemed more ignorant.

At the start of each session, the observer made notes of who was present (or absent), the type of educational session (e.g. self-study, group explanation, test day, etc.), special need pupils or assistants, etc. During each (90-minute) session she made notes roughly in blocks of 15 minutes intervals describing:

- the environmental settings such as weather conditions, settings of the blinds, the usage of the lighting system throughout the session, etc
- type and progress of the (educational) activities ongoing,
- methods of working (i.e. by themselves, small or larger groups, teacher involvement, working from a book or laptop, or other media, etc)
- noticeable pupil “behaviors” (e.g. loudness, movement, restlessness, concentration, social behavior, etc),
- and possible intervening events such as external noise, unexpected interruptions in the classroom, etc.

After each session she spoke with the responsible teacher for 5 – 10 min about those observations she noted but was not sure if interpreted correctly. However, more detailed discussion on her observations took place during a one-to-one interview with each teacher later in time.

She used an observation template (one per session) to guide her taking notes (Fig 2.16). In addition to taking notes, our observer also video recorded all 12 sessions observed. This allowed us during the analysis of the data collected on our note templates to re-view certain events and look more detailed at specific occurrences again.

OBSERVATION - FIELD NOTES				
Site specifications			Population demographics	
Room: Date/Time: Teacher: T assistant: Curriculum:			Grade: Number: ♂/♀: Special needs: Absentees:	
min	Lighting	General Log: student activity + atmosphere	Noise Log: teacher + students (good vs bad)	Sitting/Movement Log: students
00-15	<input type="radio"/> Panels			
	<input type="radio"/> Penciler			
15-30	<input type="radio"/> Panels			
	<input type="radio"/> Penciler			
30-45	<input type="radio"/> Panels			
	<input type="radio"/> Penciler			
45-60	<input type="radio"/> Panels			
	<input type="radio"/> Penciler			
60-75	<input type="radio"/> Panels			
	<input type="radio"/> Penciler			
75-90	<input type="radio"/> Panels			
	<input type="radio"/> Penciler			
General End notes:				

Figure 3.16: Observation template

- ***Sound logging***

Reviews of previous research in the field of (learning) behavior and indoor (learning) environments revealed that the level of noise produced by the users of the environment studied is a behavioral parameter that may increase or decrease due to changes in the environmental conditions, such as the lighting (Gifford, 2007; Klatte, 2013; Barrett, 2015). Secondly, acoustically orientated research in learning environments indicates that an increase in noise levels around pupils may have an impact on their ability to learn. More specifically, environmental noise may have an impact on pupils' level of concentration, which is one parameter found to measure pupil's engagement (one of our five behavioral factors as discussed in paragraph 2.1).

It should be noted that most environmental noise in a classroom is produced by the pupils (and teacher) themselves (by conversation), so measuring a higher sound level could be a result of more pupils talking and/or being louder. Both could be an indication of distraction or less concentration, but it highly depends on the activity or task they are doing. Some educational tasks require conversation, others do not. It is thus relevant, to only compare sound data from timeslots with reasonably comparable activities. As it was unknown beforehand, when these moments would take place during a session, we decided to record the noise levels present in our four classrooms during the entire two-times-two Wednesdays and Thursdays 90-minute educational sessions. In addition, we decided to also record time-lapse videos of these sessions at the same time, so we could evaluate afterwards (as our observer could only attend 1 out of 4 sessions running simultaneously) what activities had taken place during the 90-minute sessions. As we are interested in comparing noise levels as a measure of behavioral change, we eventually narrowed down our sound timeslots to those moments (often 20 to 40-minute slots) during which pupils were doing one type of activity, i.e. working with their educational books, in small groups or by themselves, in the general area of the classroom. The teacher was present helping individuals, but not actively in teaching voice. The timeslots with this type of activity are presented in paragraph 5.5.

In collaboration with DTU's Acoustic section, we installed four sound recorders, one per classroom, during our four study days. We recorded detailed sound (dB) levels (not the actual conversations for privacy reasons) in each classroom between 08:00 and 14:00, covering all three educational sessions for each classroom and day. As these recordings were time-coded, we would be able to cut-out only the timeslots covering these sessions during our analysis of the sound data.

- ***Interviews***

Interview research is essentially a way of collecting qualitative and quantitative information by questioning a person or small group of persons (Wertz, 2013). We mainly interviewed our six teachers, but also hosted two pupil group interviews.

Interviews with teachers

Our aim was to gather in-depth information about the experiences of the six teachers with the two different lighting conditions in their classroom. And specifically, whether they find these to influence their pupil's behavior and/or their own way of teaching. We organized our interviews around three topics:

- *Practicality*: ease of use, when to use, visual and physical comfort of the respective lighting scenario;

- *Atmosphere*: likability, noticeability, positive and negative feelings and/or thoughts about the classrooms' appearance due to the respective lighting scenario;
- *Behavior*: potential influence of the respective lighting scenario on pupils' behavior, and in particular relating to distraction vs concentration.

We interviewed our six teachers three times: once as a group before commencing our studies, once individually towards the end of study 1, and again individually towards the end of study 2. This allowed us to interview teachers before any intervention took place, once after using one lighting scenario, and next the other scenario. Our group interview was aimed at learning more about the teachers' experience with their classrooms and in particular the lighting conditions prior to doing an intervention. We were interested to find out what the pros and cons were, and what could be improved from their perspective. A second aim was to present our planned intervention (adding focused light pendants) and to get their feedback on their willingness to use it, their first thoughts on when or how they might want to use it, and their preferences in terms of positioning (e.g. with respect to furniture layouts etc.). The group interview was scheduled to last about 45 minutes. The individual interviews were scheduled in agreement with each teacher either during a lunch break or in the afternoon after their last teaching session and took about 20-25 minutes of their time. These took place in each teacher's respective classroom, with the relevant lighting scenario activated so that we could discuss it whilst experiencing it.

To guide our individual interviews, we developed an interview template, which we adapted slightly in order to address experiences with either the default lighting or the new the lighting system. We used a semi-structured interview approach that included mostly simple open-ended questions that interviewees could relatively easily understand and answer, but also allowed the interviewer to have freedom to probe into answers and adapt to different interviewees and situations. For our group interview, we prepared a short interview guide with a list of open-ended, probing questions and an A4 printed hand-out describing our planned intervention. The interview templates provided space for taking quick notes of responses and thoughts directly during the interview, but each interview was also voice-recorded so that we could listen to it again afterwards and refine our notes made during the interview.

We collected our (group and individual) interview data from January to April 2017. The experiences and thoughts of those interviewed were consequently based on a relatively short period of use and exposure. When the teachers and school administration requested to keep the new lighting system in place, we were able to return approximately six months later, in October 2017, to re-interview these teachers (5 out of 6) individually again. We could now gather their insights from having used the new system for a much longer period of time, and during a variation of educational activities and seasons. We used the "New lighting" template to conduct these interviews again and added some additional questions for each teacher to follow up on their answers during our first interviews.

Interviews with pupils

In addition to interviewing our teachers, we also had the opportunity to conduct two 15-minute group interviews with two *melletrin* pupil groups that were included in our research. As these opportunities only arose during our presence as an observer in the

classroom, we did not prepare a specific template prior to the session but used our teacher interview templates to probe these pupils with questions. These sessions were also recorded for further analysis afterwards.

TEACHER INTERVIEW – NEW LIGHTING

Date/Time:
Teacher:
Classroom:

INTRODUCTION

This research is about electrical lighting in the classrooms. It is part of a bigger ambition of us architects to learn how we can design a better "learning environment" that improves your (teacher) and the pupils' overall satisfaction with the classroom environment. Satisfaction is defined in our research as both: practical satisfaction (ease of use, can we see well?) and as comfort satisfaction (atmosphere). We are specifically interested to study if lighting can influence pupil's concentration and distraction. Hereto we are looking at pupil noise and movement as potential indicators.

PRACTICAL QUESTIONS

- How do you use the NEW lighting in your classroom? (always on, always off, changing on-off, dimmed)?
- Do you use the NEW lighting always the same way, or do you change it? (specific teaching activities during a lesson, depending on pupil's mood, time of day (lunch))
- Is in your opinion the NEW lighting good (enough) to support all these different "situations"? (specific teaching activities during a lesson, depending on pupil's mood, time of day (lunch))
- Does the NEW lighting give issues in regards to visual discomfort for you and/or the pupils?

COMFORT QUESTIONS

- How would you describe the general "atmosphere" in this classroom created by the NEW lighting?
- Does, and if so, how does the lighting (atmosphere) by the NEW lighting affect you?

- Do you think the NEW lighting has an effect on the pupil's? And if so, how? (e.g. sleepiness, irritations, concentration, distraction, activation, happiness, etc...)

- What is your impression of how the pupils experience the NEW lighting in the classroom? (e.g. do they ever complain; too little, much, bright, boring, or change the lighting themselves)

CONCENTRATION QUESTIONS

- Is in your opinion (bad) noise in general a problem in the classroom? And is it an indicator to you for poor concentration of the pupils? (is it a "sign" for you?)
- Is moving around of pupils in general a problem in the classroom? And is it an indicator to you for poor concentration of the pupils? (is it a "sign" for you?)
- Did you experience that pupil's noise and movement is different with the NEW vs STANDARD lighting?
- Did you experience any other changes?

... DREAMING

- Could you describe your "ideal lighting situation" in the classroom (what would you like it to be)?

Figure 3.17: Interview template

• **Pupil performance**

The experimental set-up was similar to a previous investigation on the the effect of increased classroom ventilation rate indicated by reduced CO₂-concentration on the performance of schoolwork by pupils (Petersen, 2016). The performance tests were executed in two rooms (1.2.06 and 1.2.10 at the second floor) occupied by four different classes of 3th-6th grade pupils aged 9–12 years. The pupils were systematically exposed to ambient ceiling lighting or focused pendants according to the intervention schedule (Table 3.1) while conducting two different performance tests. The experiment was a crossover design meaning that the lighting condition in one classrooms was always opposite to the condition in the other classroom. Furthermore, to improve the robustness of the experimental design the study was conducted as a double-blind experiment, i.e. the pupils were not aware of the intervention and the actual purpose of the performance tests, and the research staff were not aware of the intervention schedule until after the experimental data were processed.

One important lesson learned from the previous studies (Petersen, 2016) was that the performance of the pupils increased significantly over time due to increasing familiarity with the performance tests. To minimize this effect, a rehearsal period was added prior to the baseline and crossover experiment (Table 3.1). During this rehearsal period, the pupils completed each test with the sole purpose of familiarizing them with each test's formats and thereby minimizing systematic changes in the performance in the crossover

experiment due to learning and increased familiarity with the tests. After the rehearsal, the purpose of the baseline was to obtain data that could be used to adjust data from the crossover experiment. This was important in order to identify, whether any bias due to learning increased familiarity, or whether a lack of motivation was observed. Another benefit of the baseline was that the pupils had the chance to become even more familiar with each test's formats prior to the crossover experiment. The whole experiment was conducted as a repeated-measures design, that is, the comparisons between conditions were always within-subject comparisons in order to eliminate any bias due to individual differences in the ability to perform schoolwork. All tests were executed during normal class times. Objective measurements of CO₂ concentration, temperature and illuminance levels were logged in each study classroom throughout the whole crossover experiment while the pupils conducted the tests.

Phase	Week	Class B+J Room 1.2.06	Class D+A Room 1.2.10
Rehearsal	0	Ambient ceiling lighting	Ambient ceiling lighting
Baseline	1	Focussed pendants	Focussed pendants
	2	Ambient ceiling lighting	Focussed pendants
Intervention 1	3	Ambient ceiling lighting	Focussed pendants
	4	Focussed pendants	Ambient ceiling lighting

Table 3.1: Intervention plan and lighting conditions

Physical measurements

A silicon-based single-beam dual-wavelength sensor (Vaisala GMT 222) connected to a miniature battery-powered data logger (Tinytag Plus) was used to log the CO₂ concentration in one-minute intervals in each study room. The sensor and logger were placed at floor level, as shown in figure 2.18, to make it less visible for kids. Two similar loggers were used to log the room air temperature (Tinytag Plus) everyone minute in each studied room. The loggers were placed, as shown in figure 2.19, at desk height. State loggers (HOBO UX90-001) were used to log when any of the windows were open. Four HOBO AU-002 light meters where placed in each room during test performance to log lux levels; one on the window sill, and the other three at different working areas. In one of the rooms, one of the HOBO sensors was placed at one of the ceiling panels (facing the ceiling panel) to record electric lighting use patterns.



Figure 3.18: CO₂ sensor and data logger location in room 1.2.06



Figure 3.19: On the left, temperature (yellow Tinytag) and illuminance meter (HOB0) at working area at the back of room 1.2.10. On the right, lux meter on windowsill in room 1.2.06.



Figure 3.20: Location of CO₂, temperature and illuminance meters in room 1.2.06 (left) and 1.2.10 (right).

Measurements of pupil performance

Each week, seated at the same location, pupils underwent two different performance tests: (i) addition—the pupils added two three-digit numbers, (ii). Figural creative thinking—the pupils draw as many objects or pictures as they can envision using the lines and circles provided. The two tests were designed to assess performance in terms of ability to concentrate while doing mathematical addition exercises and conducting a creative task, respectively. Performance was measured in terms of the number of correct answers and the number of errors for addition exercises. For creative thinking tests, performance was measured in terms of fluency (number of interpretable pictures created), flexibility (number of different categories) and elaboration (number of details).

The two tests were executed during usual mathematics lessons under the administration of their usual teacher. All four classes used the same test material in each week. The time allocated for each test was 10 minutes, with a 10-minute break in between. The addition test was the first one, followed by the creativity test after the break. Teachers were asked to stop the individual tests for the entire class if one student had finished all tasks within the 10 minutes. However, the number of tasks in each test was set to make it unlikely that the pupils were able to complete them all within the given time. During the rehearsal

week, the teachers were asked to instruct the pupils on how to perform the tests and provide their professional feedback regarding any need for adjustment of each test's format, difficulty, etc. To keep the pupils blind to the experiment, the teachers were instructed to integrate the tests as a natural part of their lessons, for example, by referring to the tests as 'exercises'. Based on the experiences from the rehearsal week, the teachers expressed no need for adjusting the tests. The teachers were asked to execute the tests in the same manner and on the same day and time during the remaining weeks of the experiment.

Statistical Analysis

The intention was to make within-subject comparisons of performance in the cross-over design. Consequently, incomplete pairs of test responses i.e. when a pupil did not conduct a test in both conditions during the intervention were discarded. A statistical analysis was then conducted to quantify the statistical significance of the data. First, Shapiro-Wilk's test with a P-value criterion of >0.05 was used to determine whether the residuals in the two lighting conditions were normally distributed. If the residuals in both conditions were normally distributed, then a paired t-test was applied to investigate whether the differences between data in the two lighting conditions were statistically significant. If the residuals in at least one of the conditions were not normally distributed, the data were considered nonparametric and a Wilcoxon signed-rank test was applied to investigate the statistical significance of the differences between data in the lighting conditions. Previous studies have suggested that an increase in illuminance levels increased the performance in visual tasks involving the detection of Landolt rings of different orientations and printed in different contrasts and sizes (Fig.3.21) (H C Weston 1945, Rea. M. S. 1981, Rea. M. S. 1987, Smith. S. W., and M. S. Rea. 1978, Smith. S. W., and M. S. Rea. 1980, Smith. S. W. and M. S. Rea. 1987)

This suggests that pupils would likely perform better under higher illuminance levels, as they would be able to faster and better detect the numbers and figures on their exercise sheets. The P-values for the number of correct answers are therefore one-tailed tests because an improvement in performance due to higher illuminance levels was expected. The accepted level of confidence in statistical tests conducted was $P < 0.05$.

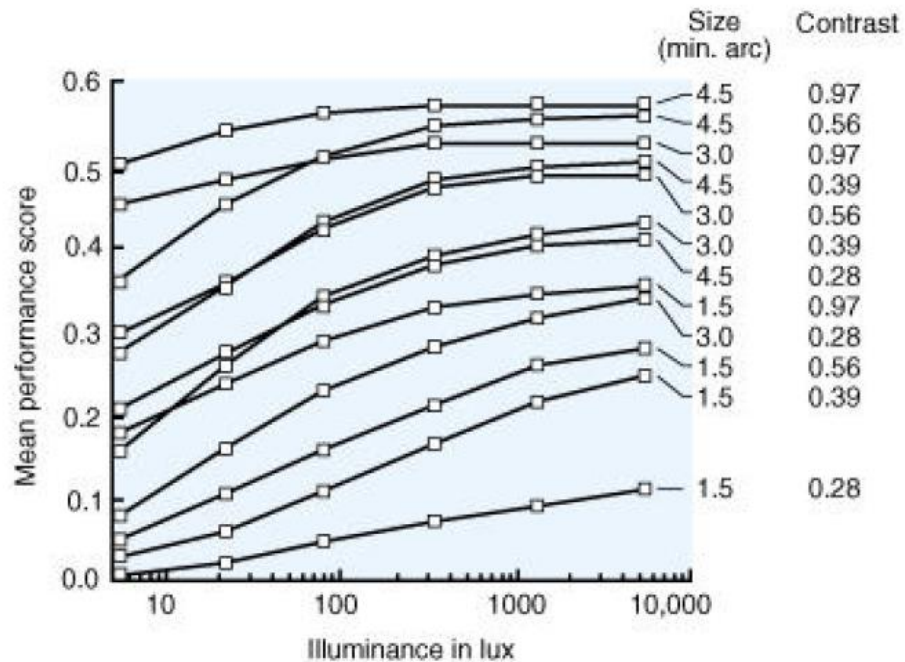

Figure 3.21: Mean performance scores for Weston's Landolt ring charts of different visual size and luminance contrast plotted against illuminance (Image Source: IESNA Lighting Handbook, 9th ed., 2000)

3.1.9.5. Partner Collaboration

Summarizing partner's responsibilities for **data collection** and **analysis**:

<i>Who?</i>	<i>Tasks and/or Equipment</i>	<i>Analysis</i>
Henning Larsen	General team coordination	X
	Architectural documentation	Building design / layout
	Pre-estimations of daylight behavior	Daylight software analysis
	Coordination with school	Pupil and teacher data
	"Observation & interviewing"	Observation + interview data
	Time-lapse video recorders	Timeslot selection
	1:1 video recorders	Pupil behavior
	Illuminance and luminance meters	Light data
	Illuminance and luminance meters	Light data
	HDRI 180 degree luminance mapping camera	False color images of luminance distribution
	Data logger	Energy consumption data
	Educational tests	Test analysis
DTU acoustics	Sound recorders	Analysis of sound data
Elteam Vest	Installation of 24 pendants and controls	X
	Installation of energy monitoring system	X
Fagerhult	24 pendants	X

3.1.10. References

- Barrett, P., Zhang, Y., Davies, F., and Barrett, L. (2015). *Clever Rooms – Summary report of the HEAD Project*. University of Salford, Manchester. ISBN 978-1907842634
- Boyce, P.R. (2014). *Human Factors in Lighting*. 3rd edition. CRC Press. Boca Raton, Florida. ISBN 978-1439874882
- Boyce, P.R. (2014). Editorial: Light distribution - a missing variable. *Lighting Research and Technology*, vol. 46, p. 617.
- Flynn, J. E., Spencer, T. J., Martyniuk, O., and Hendrick, C. (1973). Interim Study of Procedures for investigating the effect of light on impression and behavior. *Journal IES - Transaction*, 87-94.
- Flynn, J. E. (1977). A study of subjective responses to low energy and non-uniform lighting systems. *Journal IES Lighting Design + Application*, vol. 7, 167-179.
- Flynn, J. E., Hendrick, C., Spencer, T. J., and Martyniuk, O. (1979). A guide to methodology procedures for measuring subjective impressions in lighting. *Journal IES Lighting Design + Application*, vol. 8, 95-110.
- Gifford, R. (2007). *Environmental Psychology – Principles and Practice*. 4th edition. Optimal Books. ISBN 978-0968854310.
- Govén, T., Thorbjörn, T., Raynham, P., and Sansal, E. (2009). The influence of ambient lighting on pupils in rooms.
- Groat, L. N. and Wang, D. (2013). *Architectural Research Methods*. 2nd Edition. Wiley. ISBN 978-0-470-90855-6.
- H C Weston 1945, *The Relation Between Illumination and Visual Efficiency: The Effect of Brightness Contrast*, Industrial Health Research Board, Report No. 87 (London: His Majesty's Stationery Office).
- Heschong Mahone Group – California energy commission (2003). *Windows and Rooms: A Study of Student Performance and the Indoor Environment*. Technical Report.
- IESNA lighting handbook 9th edition, (2000), ISBN 0879951508
- Klatte, M., Bergström, K., and Lachmann, T. (2013). Does noise affect learning? A short review on noise effects on cognitive performance in children. *Frontiers in Psychology*; vol. 4
- Petersen S., Jensen K.L., Pedersen A.L.S., and Rasmussen H.S. (2016) The effect of increased classroom ventilation rate indicated by reduced CO₂-concentration on the performance of schoolwork by children. *Indoor Air*, vol. 26, 366–379
- Rea, M. S. 1981. Visual performance with realistic methods of changing contrast. *J. Illum. Eng. Soc.*: 10(3):164-177.

- Rea. M. S. 1987. Towards a model of visual performance: A review of methodologies. *J. Illum. Eng. Soc.* 16(1):128-142.
- Smith. S. W., and M. S. Rea. 1978. Proofreading under different levels of Illumination. *J. Illum. Eng. Soc.* 8(1):47-52
- Smith. S. W., and M. S. Rea. 1980. Relationships between office task performance and rating of feeling and task evaluations under different light sources and levels. *Proceedings: 19th Session, Commission Internationale de l'Éclairage. Paris: Bureau Central de la CIE.*
- Smith. S. W., and M. S. Rea. 1987. Check value verification under different levels of illumination. *J. Illum. Eng. Soc.* 16(1):143-149.
- Vogels, I. (2008). Atmosphere metrics – Development of a tool to quantify experienced atmosphere. Published in: Westerink, J., Ouwerkerk, M., Overbeek, T.J M., Pasveer, W.F. *Probing Experience – From Assessment of User Emotions and Behaviour to Development of Products*. Philips Research Book Series, Volume 8. Springer Science & Business Media, 25-41. ISBN 978-1-4020-6592-7.
- Wertz, F.J., Charmaz, K., McMullen, L.M., Josselson, R., Anderson, and R., McSpadden, E. (2011). *Five ways of doing qualitative analysis*. The Guilford Press. ISBN 978-1-60918-142-0
- Wessolowski, N., Koenig, H., Schulte-Markwort, M., and Barkmann, C. (2014). The effect of variable light on the fidgetiness and social behavior of pupils in school. *Journal of Environmental Psychology*, vol. 39, 101–108.

4. Work package 2 – New lighting at Frederiksbjerg School

During the Christmas holidays (week 07), we installed the new pendants **Type B**, DALI based control circuits and local wall switches, as well as the indoor climate recorders (light, temperature, CO₂ and humidity recorders) and energy logging set-up. We also checked all the existing ceiling luminaire **Type A** drivers to make sure they are all on the same setting to achieve 300lux average illuminance at the working plane (+0.6m) and connected each group of 6 to the DALI hub and laptop to enable continuous activation and dimming state logging. Following are some impressions of the classroom situations before, during, and after installation of the new equipment.

4.1.1.1. Pre-research situation

Impression of the classroom appearances before our experimental interventions (with and without the ceiling lighting activated) are shown in figure 4.1.



Room 1A (01.1.05)

Room 1B (01.1.10)



Room 2A (01.2.06)

Room 2B (01.2.10)

Figure 4.1: Examples of classroom situation before our study intervention

4.1.1.2. During installation

Impressions of “work in progress” for the set-up, installation and checking of the indoor climate recording devices and the installation of new pendants and control circuits in all four classrooms are shown in figure 4.2.



Figure 4.2: Examples of set-up, installation and checking of the indoor climate recording devices

- **After installation**

Impression of the classroom appearances after installation and set-up (with the new pendant and/or ceiling lighting activated) are shown in figure 4.2.



Room 1A (01.1.05)



Room 1B (01.1.10)



Room 2A (01.2.06)



Room 2B (01.2.10)

Figure 4.3: Examples of classroom situation after installation and during our study intervention

5.

Work package 3 – Pilot test

During week 5, we ran and tested our prepared qualitative data collection protocol (Fig. 5.1), and specifically our observation protocol, for the Wednesdays and Thursdays of our two studies. This experience helped us to refine the protocol further. It also gave the pupils and teachers some time to get “used” to having an observer in their classroom and thus trying to remove the “observer-presence effect” possibly contaminating our data.



Pilot observation in classroom indskoling

Pilot observation in classroom mellemtrin

Figure 5.1: Examples of pilot observations

6. Work package 4 – Full-scale test, gathering of physical data

6.1.1.1. Introduction

Work package 4 summarizes quantitative data from interventions done at the school during weeks 8 to 14 (Study 1 and 2). Quantitative data consist of lighting levels, temperature, humidity, CO₂, energy consumption of both original and new lighting installations, and sound levels. Results from academic performance tests during weeks 45 to 48 are also included in this package.

6.1.1.2. Indoor daylighting and lighting conditions

Illuminance measurements were recorded under overcast sky conditions in four rooms on 8 March (Study 1) and 29 March (Study 2) for daylight only and for a combination of daylight and electric lighting. Evening measurements without daylight were also taken on these days.

6.1.2. Indoor lighting conditions

Looking at measurements taken during evening time (no daylight access), it is possible to identify the illuminance levels provided by the electric lighting scenarios and the illuminance distribution the different scenarios provide. Under identical scenarios, most of the rooms showed similar lighting levels, although room design and luminaires layout are slightly different (Tables 6.1 and 6.2).

	Default Scenario			
	A. Ambient Ceiling Lighting (100%)			
	MAX.	MIN.	AVE.	Uniformity
Room 1.1.05	465	98	300	0.33
Room 1.1.10	477	119	325	0.37
Room 1.2.06	425	64	235	0.27
Room 1.2.10	520	143	368	0.39

Table 6.1: Lighting conditions in each room for “default scenario” during evening time at 0.6m above floor level represented as maximum (MAX), minimum (MIN), average (AVE.) illuminance (lux) and illuminance uniformity.

	New Scenario											
	A. Ambient Ceiling Lighting (70%)				B. Ambient CL(30%) + pendants (100%)				C. Focused pendants (100%)			
	MAX.	MIN.	AVE.	Uniformity	MAX.	MIN.	AVE.	Uniformity	MAX.	MIN.	AVE.	Uniformity
Room 1.1.05	314	83	189.9	0.44	680	30	144	0.21	626	9	97	0.09
Room 1.1.10	339	81	232.1	0.35	1337	33	175	0.19	1550	11	192	0.06
Room 1.2.06	361	62	194.9	0.32	1550	41	263	0.16	1557	9	139	0.06
Room 1.2.10	346	105	230.5	0.46	1231	31	289	0.11	1263	7	190	0.04

Table 6.2: Lighting conditions in each room for “new scenarios” A, B and C during evening time at 0.6m above floor level represented as maximum (MAX), minimum (MIN), average (AVE.) illuminance (lux) and illuminance uniformity.

“Default Scenario A” – Ambient Ceiling Lighting (100% output)

This scenario corresponds to a fairly uniform spatial illuminance distribution. The default light output of the luminaires is set to 100%. However, light sensor input dims the luminaire output according to available daylight levels (sensor locations are indicated by the blue rings on the floor plans). Without dimming for this scenario, illuminance levels reach up to 450-500lux with uniformity around 0.4 for all rooms (Fig. 6.1) except 1.2.06 (Fig. 6.2), where uniformity is around 0.3 due to a lower number of ceiling panels (four panels instead of six).

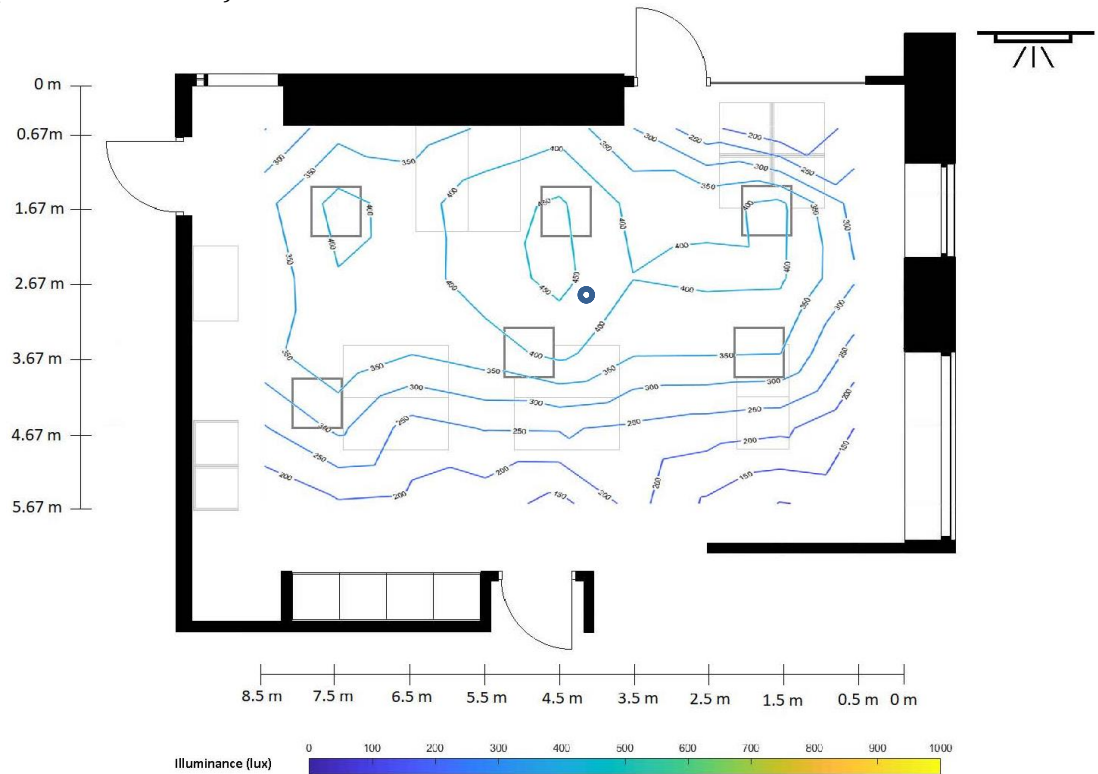

Figure 6.1: Illuminance levels [lux] at 0.6m above floor level in room 1.1.05 under Default Scenario A - Ambient Ceiling Lighting (100% output) for electric lighting only.

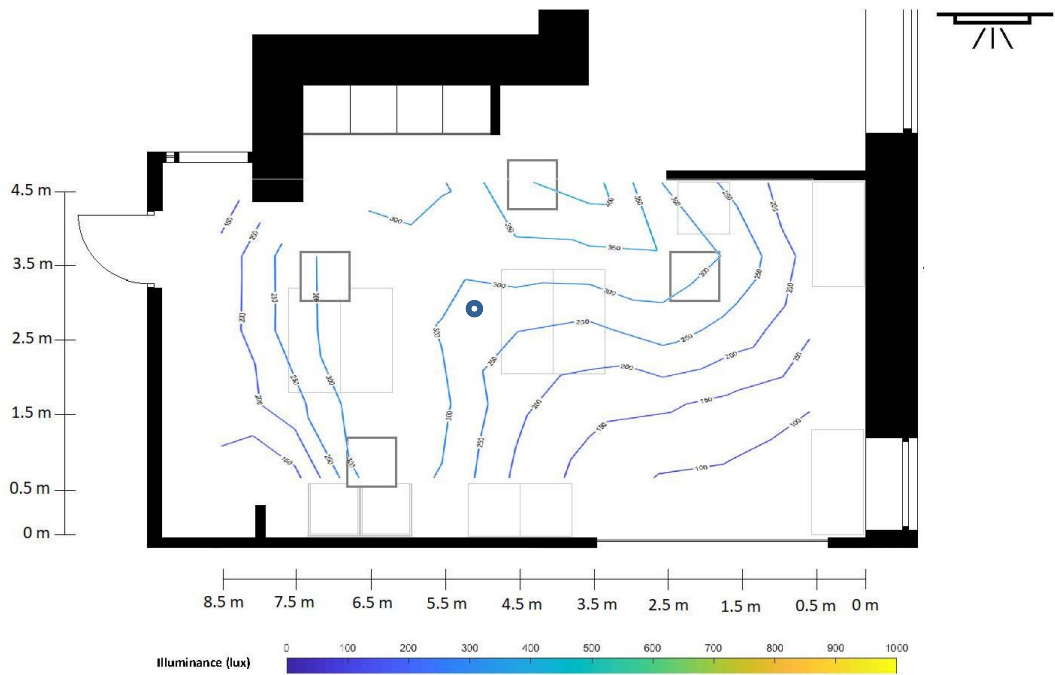

Figure 6.2: Illuminance levels [lux] at 0.6m above floor level in room 1.2.06 under Default Scenario A – Ambient Ceiling Lighting (100% output) for electric lighting only.

“New Scenario A” – Ambient Ceiling Lighting (70% output)

The New Scenario A corresponds also to a fairly uniform spatial illuminance distribution. However, here the default ceiling panels were set to provide a maximum of 70% of their output. When daylight is available, this can be further dimmed by the light sensor. Manual dimming via the switch located at the door is also possible. When ceiling panel output is 70%, illuminance levels at desk height are around 350-200lux depending on the room zone (window zone, center zone, and rear zone) (Figs. 6.3, 6.4 and 6.5). Uniformity in this scenario ranges from 0.32 to 0.46.

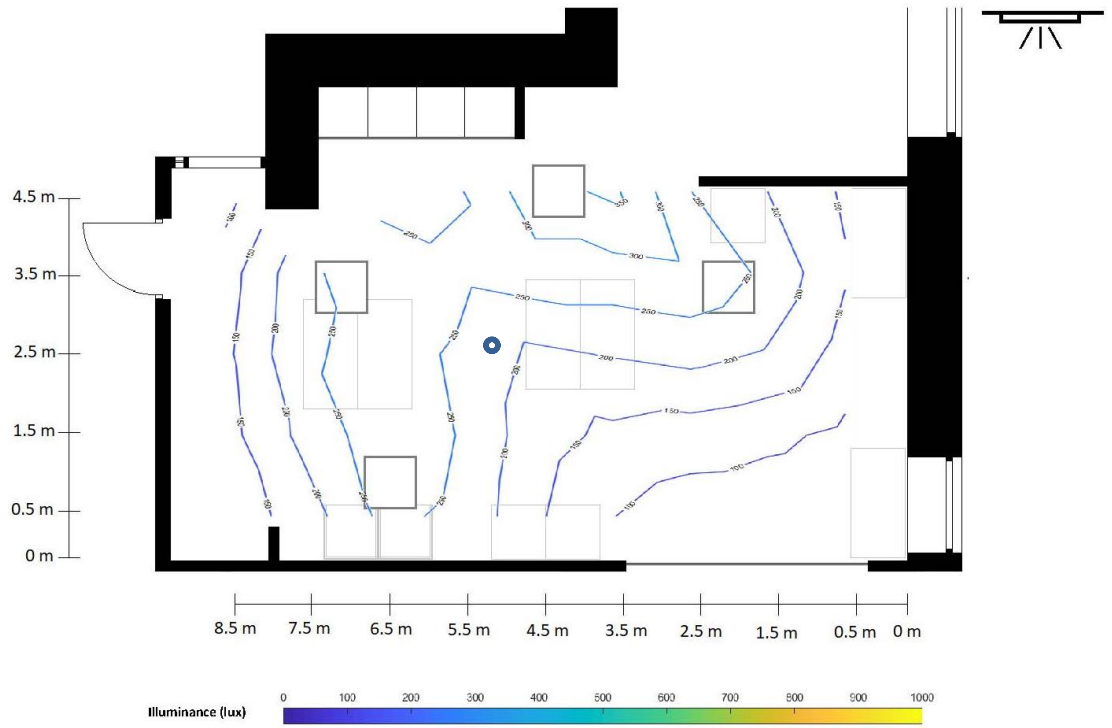

Figure 6.3: Illuminance levels [lux] at 0.6m above floor level in room 1.2.06 under New Scenario A - Ambient Ceiling Lighting (70% output) for electric lighting only.

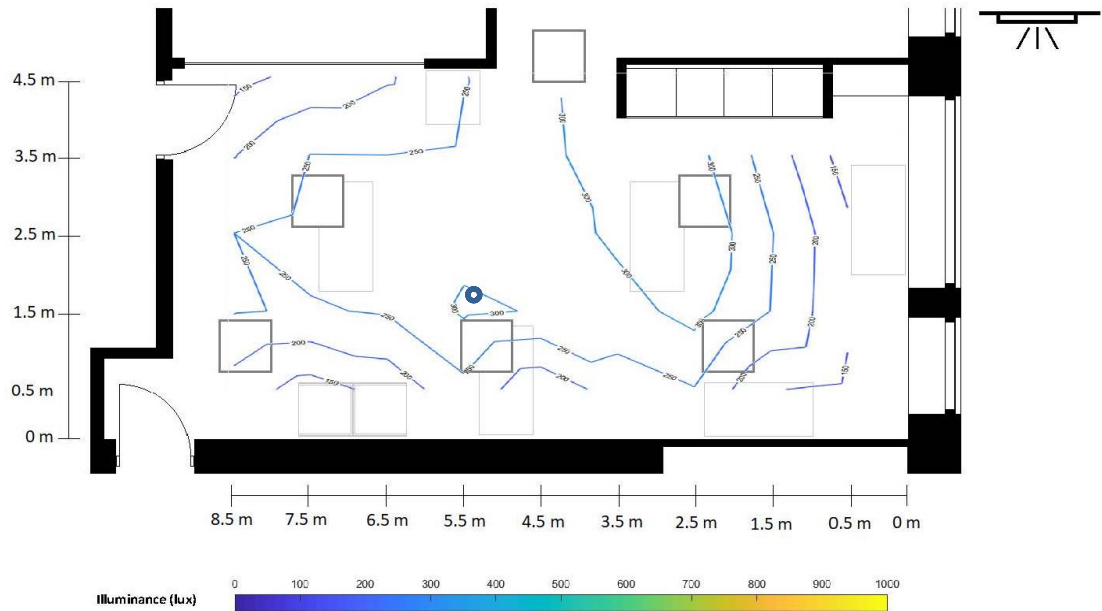

Figure 6.4: Illuminance levels [lux] at 0.6m above floor level in room 1.2.10 under New Scenario A - Ambient Ceiling Lighting (70% output) for electric lighting only.

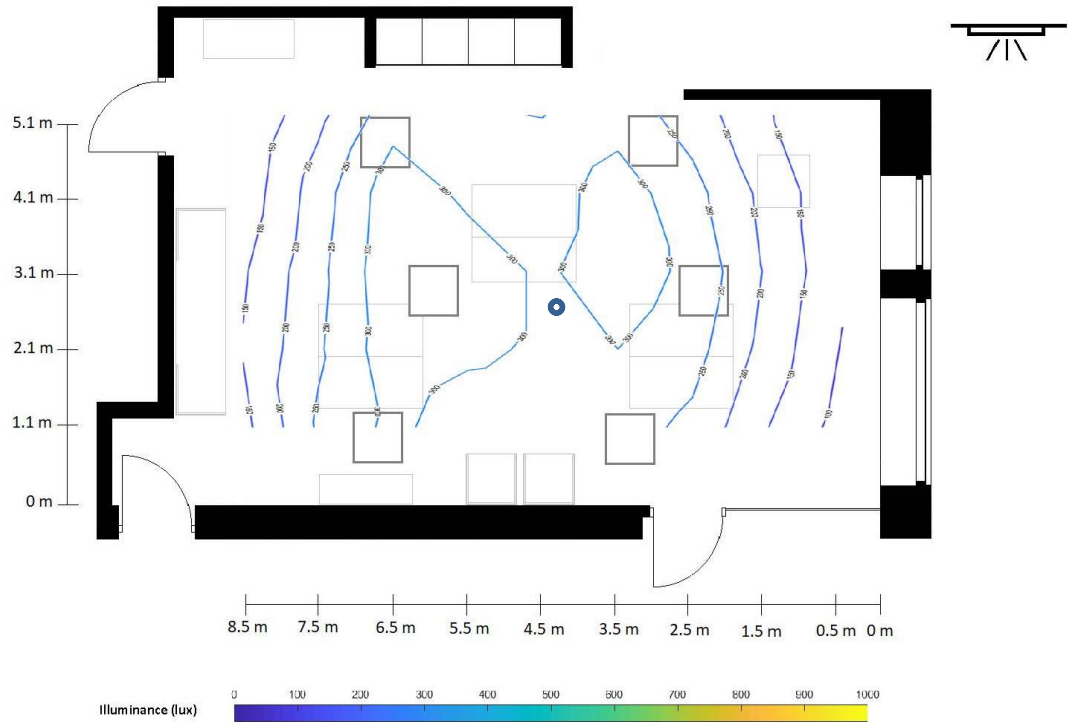

Figure 6.5: Illuminance levels [lux] at 0.6m above floor level in room 1.1.10 under New Scenario A - Ambient Ceiling Lighting (70% output) for electric lighting only.

“New Scenario B / C” – Ambient Ceiling Lighting (30% output) + Focused Pendants (100% output / Focused Pendants (100% output)

Both, New Scenario B and C, correspond to a non-uniform spatial illuminance distribution. When pendants are ON, illuminance levels are approximately 1.500 lux underneath the luminaires at desk height, and ca. 500 lux at a distance of 0.5m to 1m outside the direct beam of the pendant luminaires (pendant radius).

The areas between working spaces have levels of ca. 50 lux when only the focused pendants are ON (Figs. 6.6 and 6.8). These same areas have approximately 150 lux when both ceiling lighting and pendants are ON (Figs. 6.7 and 6.9).

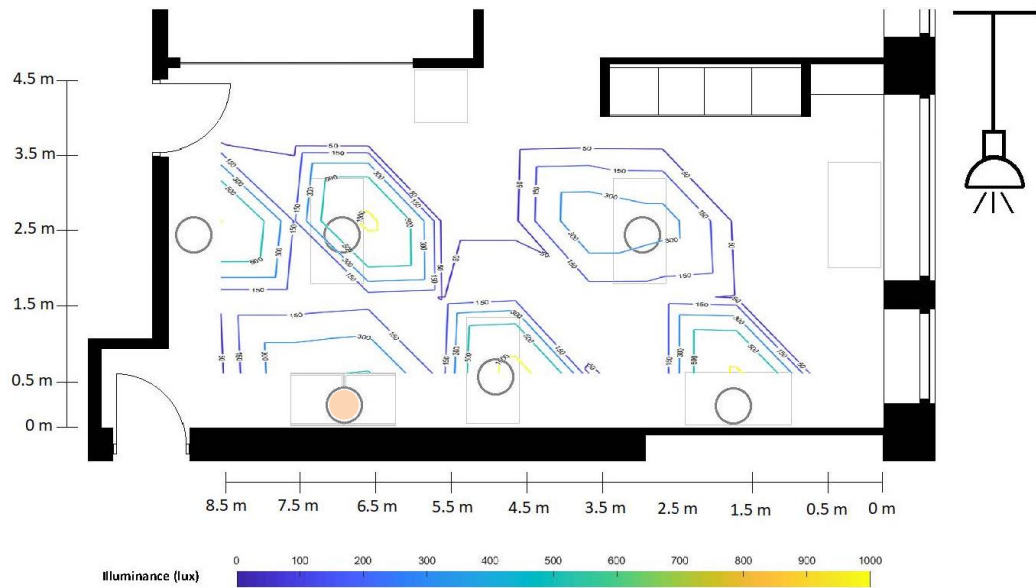

Figure 6.6: Illuminance levels [lux] at 0.6m above floor level in room 1.2.10 under New Scenario C - Focused Pendants (100% output lighting). Only electric lighting.

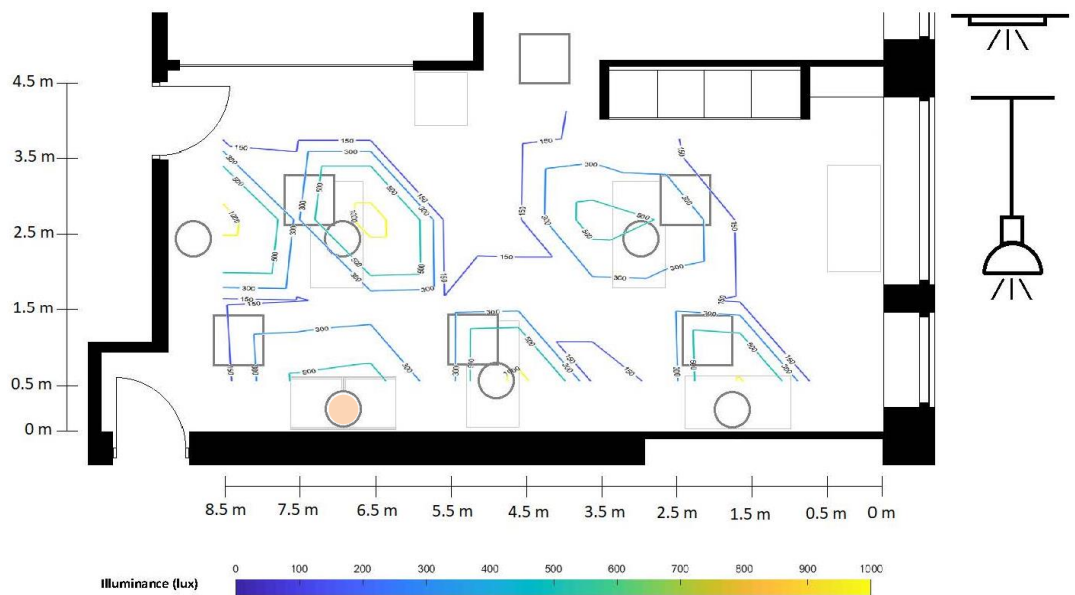

Figure 6.7: Illuminance levels [lux] at 0.6m above floor level in room 1.2.10 under New Scenario B - Ambient CL (30% output lighting) + Focused Pendants (100% output lighting). Only electric lighting.

There are cases of pendant luminaires being mounted higher than elsewhere (the colored circles on the floor plans) because of furniture or other objects in the room. The higher mounting height, of course, provides lower illuminance levels underneath the luminaire at desk height with ca. 500 lux.

When pendants work together with ceiling lighting (“New Scenario B”), illuminance uniformity of the space is around 0.17. On the other hand, when pendants work alone (“New Scenario C”), the non-uniformity of the space is more noticeable (illuminance uniformity below 0.1, see also Table 6.2).



Figure 6.8: Illuminance levels [lux] at 0.6m above floor level in room 1.2.06 under New Scenario C - Focused Pendants (100% output) for electric lighting only.



Figure 6.9: Illuminance levels [lux] at 0.6m above floor level in room 1.2.06 under New Scenario B – Ambient CL (30% output lighting) + Focused Pendants (100% output) for electric lighting only.

Light Sensors

According to the lighting design specifications, the light sensor located at the middle of the room should take the darkest area of the room as the reference (in this case the rear of the room) to determine the appropriate dimming level. The other two zones in the room center and near the window should then be dimmed further than the reference zone at the rear of the room by 10 and 15%, respectively. These areas receive more daylight and thereby, electric lighting output can be lower. However, the light levels under ambient ceiling lighting show a different set up (Figs. 6.1, 6.2, 6.3, 6.4 and 6.5) that does not seem to correspond to the design specifications.

During the intervention at the school, it was observed that most light sensors were adjusted to look straight down in most of the cases. This suggests that the zone in the room center is taken as the reference area in the room. In other cases such as room 1.1.05, the light sensor looks at the right zone (rear of the room), but the identification of the other two zones (center and near the window) seems incorrect (Fig. 6.10).

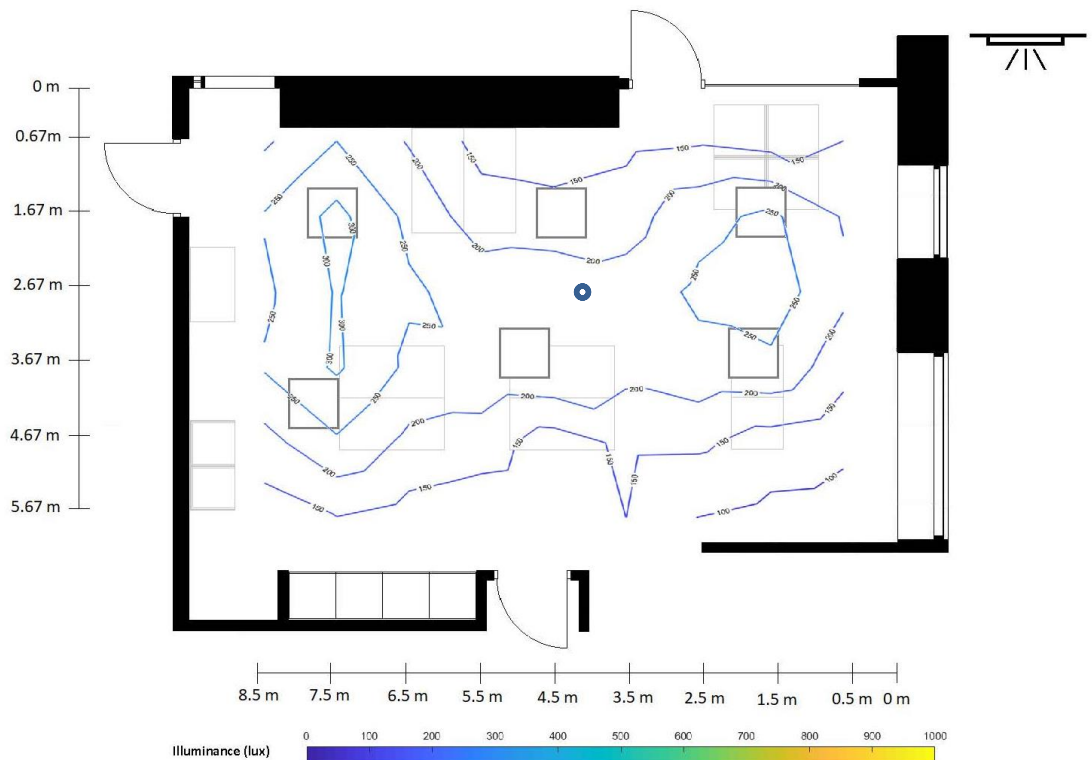

Figure 6.10: Illuminance levels [lux] at 0.6m above floor level in room 1.1.05 under New Scenario A - Ambient Ceiling Lighting (70% output) for electric lighting only. In this room, the highest illuminance levels are at the back of the room (darkest zone). However, the window zone is taken as the second darkest area with an off-set of 10% and the center zone as the area with the lowest lux levels of the space with an off-set of 15%. One LED panel in the center zone did not function at all during measurements.

6.1.3. Indoor daylighting conditions

Daylight illuminance measurements were taken under fairly overcast sky conditions on 8 and 29 March with a hand-held illuminance meter inside the rooms at desk height. The electric light sources were off. Exterior horizontal illuminance was logged continuously in order to determine the sky conditions at the times the indoor illuminance was measured and to calculate the daylight factor (DF). A HOBO sensor was also placed on the sill of one of the windows in the room to indicate whether direct sunlight would enter the room at any time. The intention was to avoid direct sunlight during measurements to ensure stable daylight conditions (see illuminance levels at window sill in Appendix E).

However, there were some technical issues with the datalogger recording the exterior illuminance levels from the Li-Cor sensor on the roof. A later examination of the data logger program suggested that a wrong code in the logging program caused the data to be recorded incompletely and incorrectly scaled. Recovery of the missing data was unfortunately impossible.

The exterior illuminance levels used for the daylight factor calculations in this report are therefore based on data from DIALux simulations for a CIE overcast sky for the same day and time, for which the interior illuminance measurements were taken. Simulation data

agreed reasonably well with the measured data that were available to justify this approach.

Since the façade layout with respect to the placement of window openings varies from room to room, daylighting conditions are expected to be different too. Especially with respect to daylight distribution near the east-facing window wall.

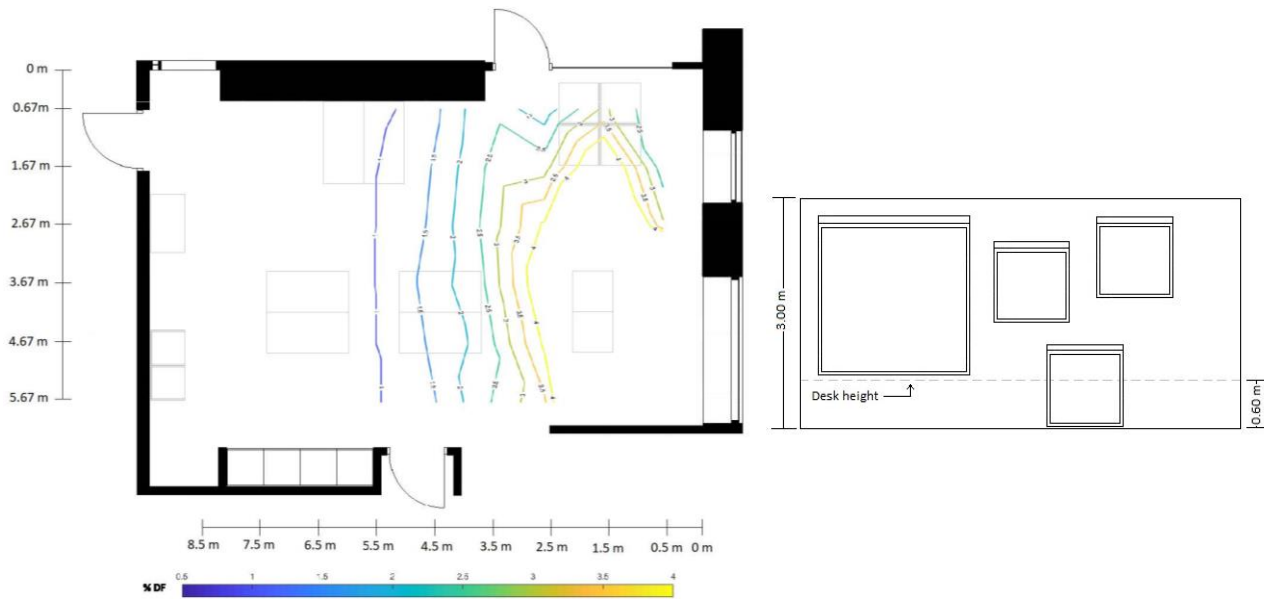

Figure 6.11: Daylight factor level [%] at 0.6m above floor level in room 1.1.05 (left). Façade window layout of the classroom as seen from outside the room (right). Glazing-to-floor-area-ratio = 15%.

Room 1.1.05 has the best daylight factor conditions of the four classrooms (Fig. 6.11), although it has the lowest glazing-to-floor-area-ratio (Appendix E). The area with $DF \geq 2\%$ is wider and reaches deeper into the room than in the other classrooms (Figs. 6.11 6.12, 6.13 and 6.14). This is mainly due to window size and distribution in the window wall. Room 1.1.05 is the one with a bigger glazing area above desk height.



Figure 6.12: Daylight factor level [%] at 0.6m above floor level in room 1.2.06 (left). Façade window layout of the classroom as seen from outside the room (right). Glazing-to-floor-area-ratio = 26%



Figure 6.13: Daylight factor level [%] at 0.6m above floor level in room 1.1.10 (left). Façade window layout of the classroom as seen from outside the room (right). Glazing-to-floor-area-ratio = 18%

On the other hand, although room 1.1.10 has a medium-high glazing-to-floor-area-ratio, it does not reach a DF of 2% at any of the measured points. However, it has the highest DF levels at the rear of the room probably thanks to two windows in the top part of the façade (Fig. 6.13).

Although there are some differences, daylight factor values obtained from a simulation of the exterior illuminance values and interior illuminance measurements were similar to the ones obtained from full simulations results (Appendix E). The values for the simulations were slightly higher and the area with a DF of 2% reaches around 1m deeper into the room in the computer simulations. On the other hand, the daylight distribution is very similar. These differences were expected because the 3D model did not include any furniture, whereas there was furniture present during measurements in the real spaces. Accuracy of surface reflectance values can also result in differences in the results.

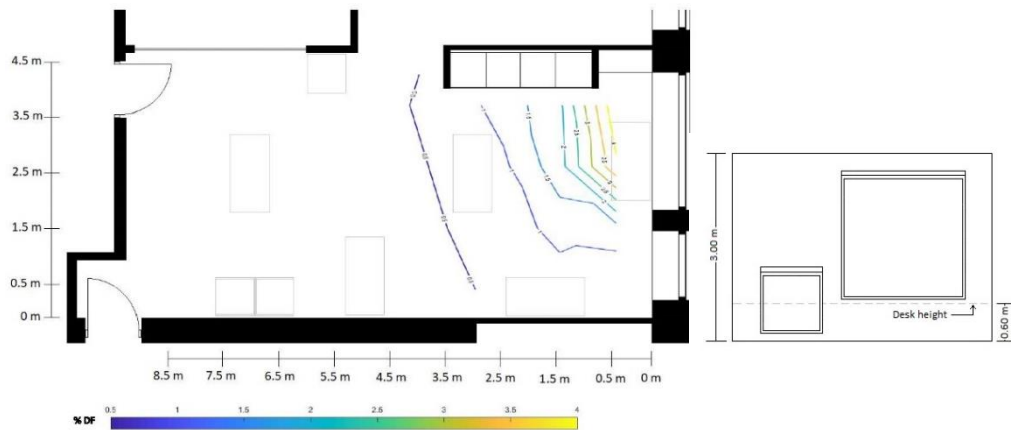

Figure 6.14: Daylight factor level [%] at 0.6m above floor level in room 1.2.10 (left). Façade window layout of the classroom as seen from outside the room (right). Glazing-to-floor-area-ratio = 18%

6.1.4. Conclusion

When using ambient ceiling lighting alone, all classrooms achieved the illuminance values recommended in lighting standards EN12464-1 and DS700. Most of the spaces have 200lux or above (highest around 450lux) at the working plane. Uniformity is 0.4 or higher for 63% of the cases and never lower than 0.3.

On the other hand, when pendants are part of the scenario, uniformity is below 0.2 for all cases and illuminance levels between the pendants show 50-150lux, depending on whether ceiling lighting is ON or OFF. With pendants, kids working area has 500lux or higher.

With pendants, a non-uniform spatial illuminance distribution is observed, creating focused bright areas where kids work and soft light between working areas, perhaps avoiding distractions from the surroundings and creating more focus on their work.

With more evenly distributed lighting scenarios, no area in the classrooms stands out over another. Lighting conditions are rather uniform.

As discussed earlier, the lighting control system did not seem to work as intended. Dimming values for some zones appear to be defined incorrectly, and sensor coverage areas are not adjusted correctly with respect to what they should “see”. This will likely result in lower energy savings than expected.

In areas where there is little daylight contribution, good electric lighting design becomes especially important. This is the case in the studied rooms, where only the first 3.5m of the room depth has a significant daylight contribution and the remaining 4.5-5.5m of the room depth depend mainly on electric lighting. This assigns great importance to appropriate light sources, flexibility of lighting scenarios and control systems.

6.1.4.1. Other indoor climate variables

Hobo loggers placed in the back and in the front of the room, see diagrams below, logged the CO₂ concentration, room temperature and relative humidity (RH).



Room 1.1.05

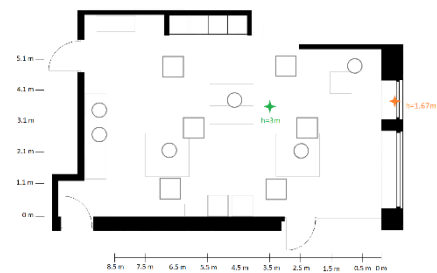

Room 1.1.10

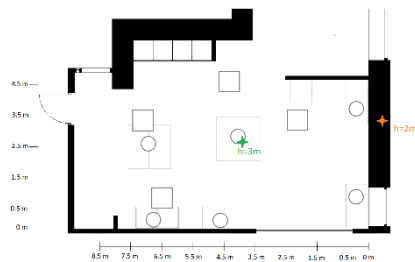

Room 1.2.06

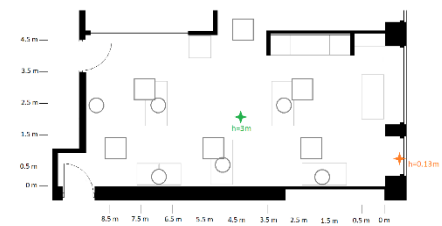

Room 1.2.10

Figure 6.15: Placement of Hobo loggers

The CO₂ levels were logged every 2 min whereas the temperature and RH were logged every 5 min.

Results

The CO₂ measurements convey very stable conditions, with average values ranging from 700ppm to 900ppm, so within the standards. Only one day had an average at 1400ppm, and two days had peak value above 1900ppm.

CO2 - Air Quality

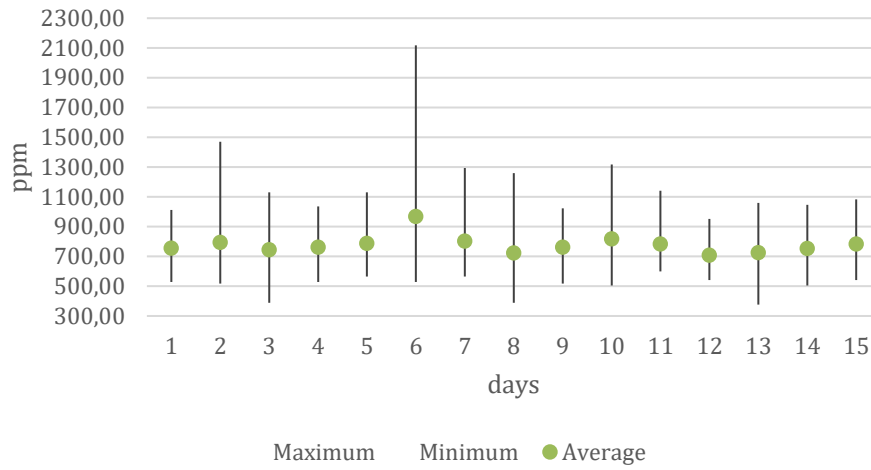

Figure 6.16: CO₂ concentration, first 15 test days

CO2 - Air Quality

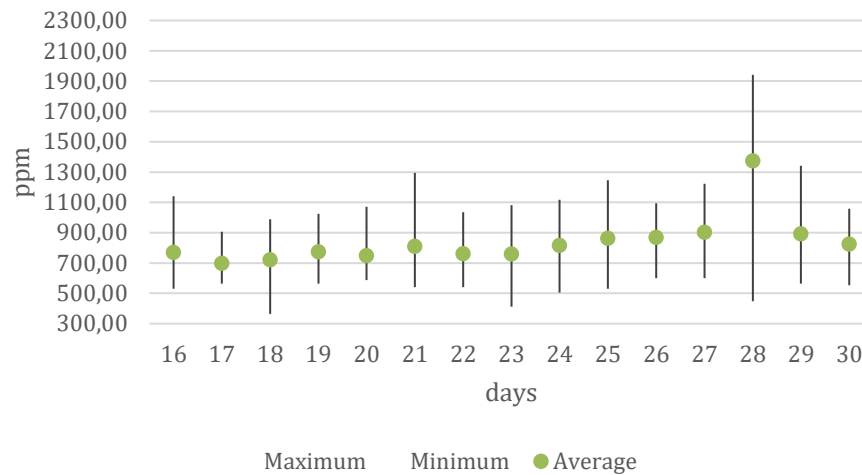

Figure 6.17: CO₂ concentration, last 15 test days

The temperature measurements show also very stable conditions, with average temperatures ranging from 20,5 C to 21,5 C.

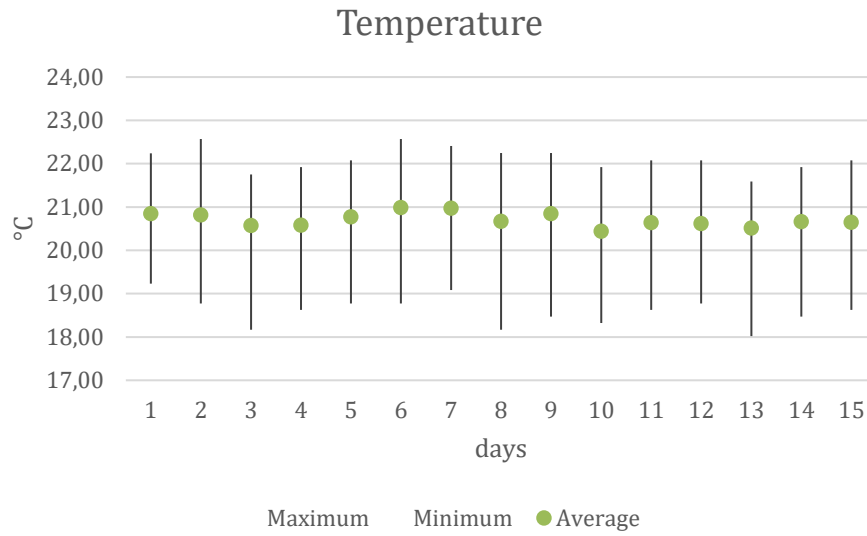

Figure 6.18: Temperature concentration, first 15 test days

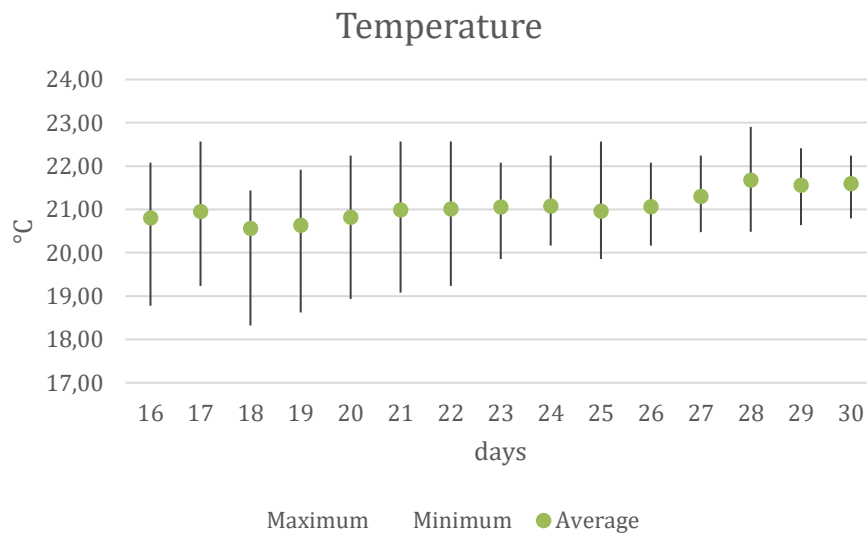

Figure 6.19: Temperature concentration, last 15 test days

The RH measurements showed RH ranging from 32 to 55, which is considered acceptable, and follows the outdoor weather conditions.

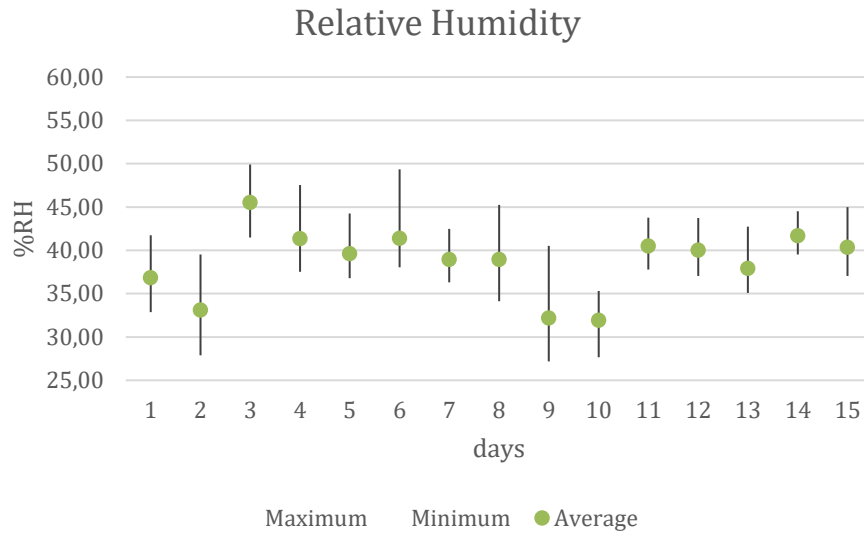

Figure 6.20: Humidity concentration, first 15 test days

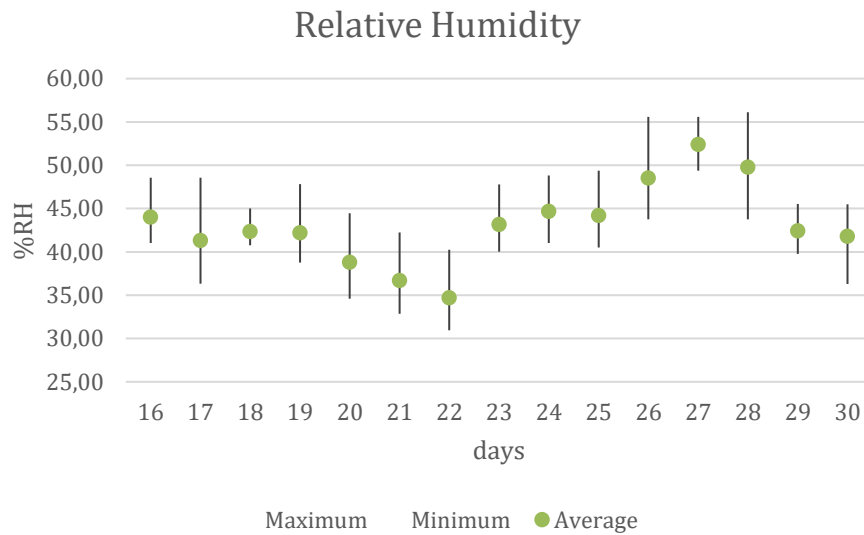

Figure 6.21: Humidity concentration, last 15 test days

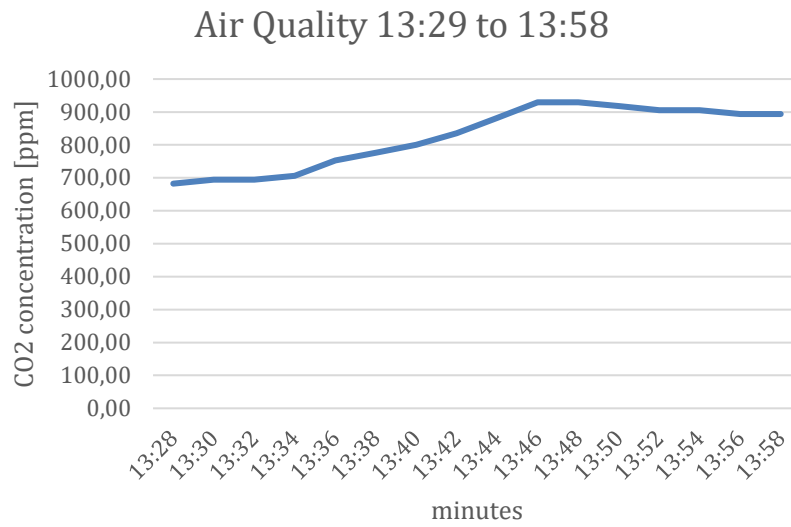

Figure 6.22: CO₂ concentration

6.1.5. Conclusion

In general, the measurements of the environmental parameters, CO₂, RH and Temperature, show stable conditions therefore those values will not influence the results of the research.

6.1.5.1. Energy analysis

Control

The light sensor used in the rooms are from BEG, and is called PD4-MASTER-DAA4G. (http://www.luxomat.com/dk/pdf/dk/ba/MAN_PD4-M-DAA4G-DK_komplett.pdf)

According to the manufacturer, the sensor controls the light output from the luminaires based on the light output in the darkest zone of the room, farthest off from the window, and then have a default offset to the other zones in the room. However, looking at the actual installation (Section 5.1) it can be seen that the sensor point directly towards the floor in the center of the room in rooms on level 2, 01.2.06 and 01.2.10. So, the registered illuminance level is the level in the center of the room.

The rooms are controlled in three and two zones dependent on the layout of fixtures. Room 1.1.05, and 1.2.06 and 1.2.10 have 3 zones whereas room 1.1.10 has 2 zones. See drawings below. The project team visited the school together with an electrician from BEG and he confirmed the zone division.

Zone 2 has a default off-set of 10% in relation to zone 1, and zone 3 has a default off-set of 15%. This default will found the basis for our theoretical calculations of the energy consumption.

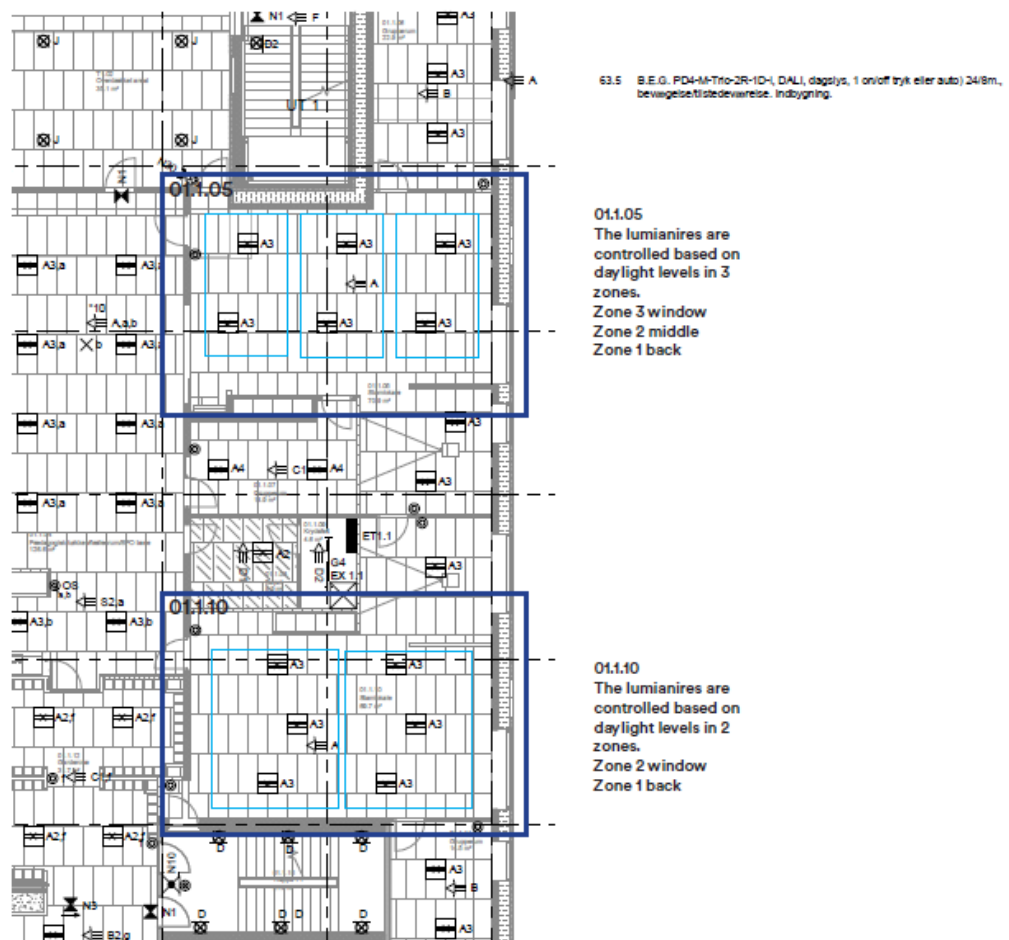

Figure 6.23: Control zones for room 01.1.05 and 01.1.10.

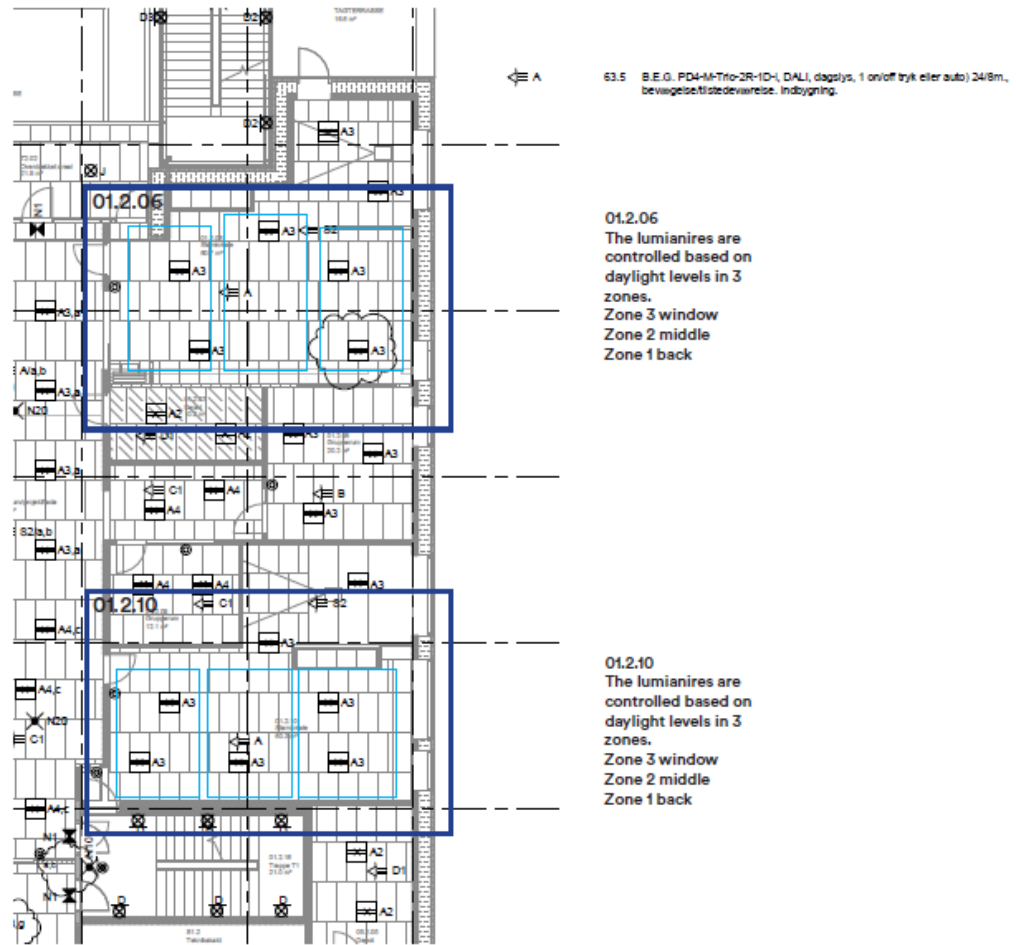

Figure 6.24: Control zones for room 01.2.06 and 01.2.10.

Daylight simulations

In order to determine the potential energy savings from use of daylight, annual simulations have been made of the daylight level in each room. The daylight simulations were performed in Radiance/Grasshopper/Honeybee, with radiance settings:

Radiance settings:

ab = 5 pt = 0.1 ds=0.25 aa=0.2 pj = 0.9 dt = 0.25 ad = 2048 dj = 0.5 dp = 256 lw = 0.01 ar = 64 as = 2048 dc = 0.5

Simulations were made for each hour from 8:00 to 18:00 each day throughout the year. The schedule was set to be from 8:00 to 18:00 because the school typically will be used for meetings and other activities in the afternoon.

The reflectance of walls, floor and ceiling were typical reflectances, representing the interior of the school. The light transmittance is in accordance with the actual window in the school:

Reflectances - wall = 0.5, floor = 0.2, ceiling = 0.7, Light transmittance window glass = 65%

The continuous daylight autonomy is a measure that also considers the illuminance levels below the threshold. As also shown from the light measurements, described in section 5.1, the illuminance threshold is 300 lux. By simulating the continuous daylight autonomy, illuminance levels below 300 lux, e.g. 150 lux would give 0.5 credit for that time step. Hereby, the simulations will consider the dimming effect of luminaires based on daylight harvesting.

The results from the daylight simulations can be seen on the plan drawings below. The colored area is the simulation plane in the rooms.

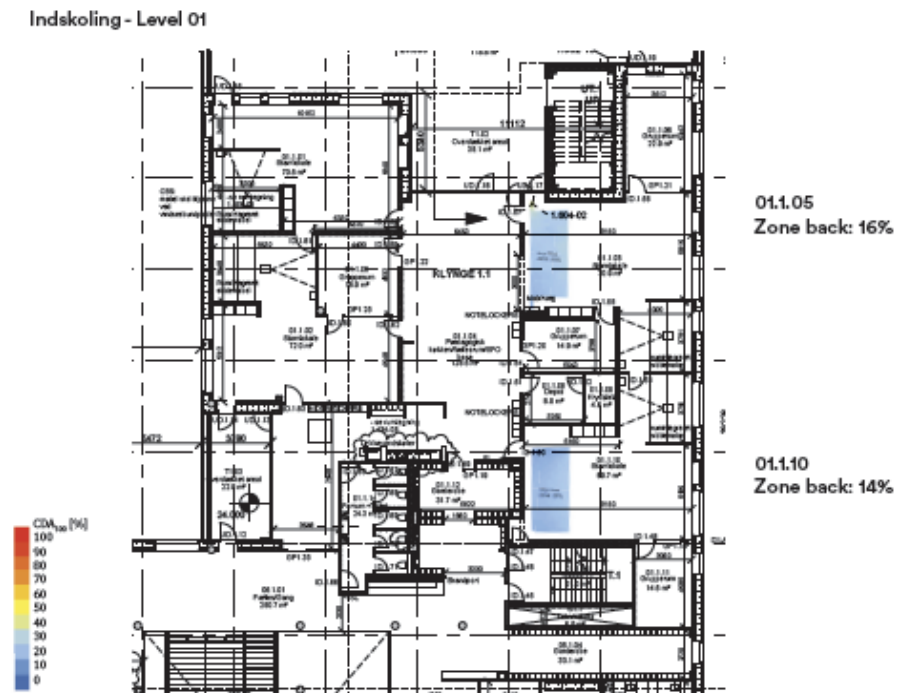

Figure 6.25: Daylight simulation level 01.

Mellemtrin - Level 02

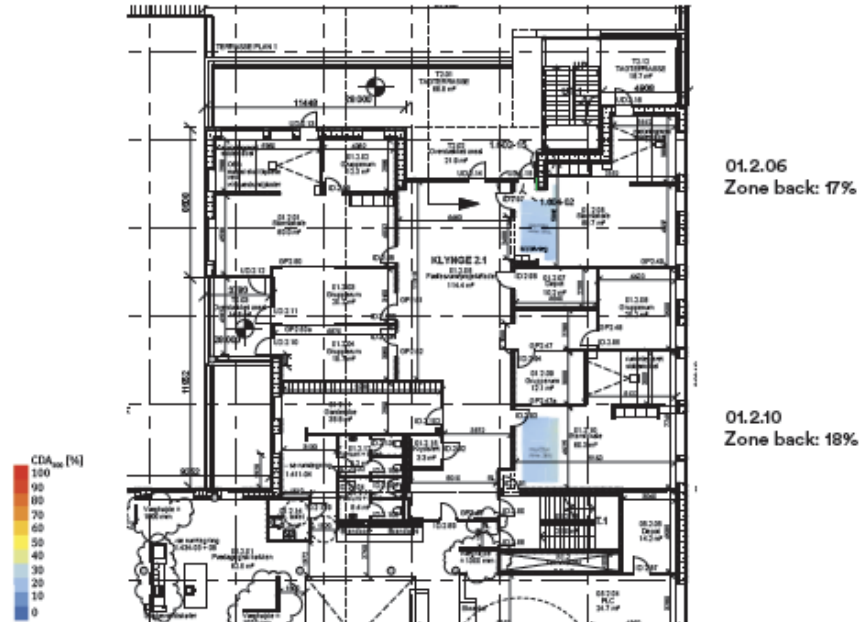

Figure 6.26: Daylight simulations level 02.

For room 01.1.05 the Continuous Daylight Autonomy for zone 1, in the back of the room, is 16%. This means that on average the zone has 48 lux from daylight for the entire year. The artificial lighting then needs to add up to 252 lux, which corresponds to $0,84 * 2 * 45 W = 76W$ for the ceiling panels at full output. The correlation between light-output and energy consumption is linear for LED-fixtures. Hence, these numbers can directly be transformed to energy consumption.

11 cases have been calculated, as to see the energy saving potential. The first 4 cases represent the situations under the test period, when the ceiling luminaires were dimmed 30% to achieve 300 lux on the working plane.

Cases 5 to 11 represents other alternatives where the users are given the option to also dim the pendants. For the test set-up we could not dim the pendants and for some of the measurements we have up to 1500 lux below the pendants. In order to have good light conditions on the task 500 lux would be sufficient. Therefore, 6 alternative cases were suggested, where the pendants also can be dimmed.

The different cases are described below:

1. The reference case is the case with daylight control of the ceiling luminaires with the threshold 300 lux.
2. A case where the ceiling luminaires are dimmed further 30% and pendants are on 100%
3. A case where the ceiling luminaires are dimmed further 20% and pendants are on 100%

4. A case with pendants only
5. A case where ceiling panels are dimmed 30% and pendants are dimmed 70%
6. A case where ceiling panels are dimmed 30% and pendants are dimmed 50%
7. A case where ceiling panels are dimmed 30% and pendants are dimmed 30%
8. A case where ceiling panels are dimmed 20% and pendants are dimmed 70%
9. A case where ceiling panels are dimmed 20% and pendants are dimmed 50%
10. A case where ceiling panels are dimmed 20% and pendants are dimmed 30%
11. A case with pendants only dimmed 50%

The average energy consumption for an hour throughout the year for the different cases is given in the graph below.

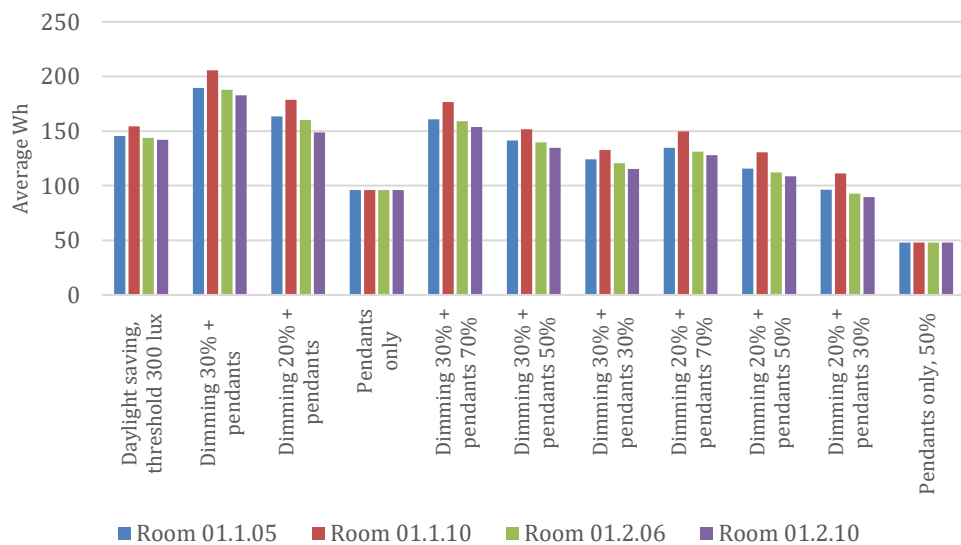

Figure 6.27: Average energy consumption for an hour throughout the year.

The corresponding energy savings are given in the next figure. The case with pendants only give energy saving of 32-38%, and further giving the users the option to dim the pendants results in further savings. Giving the users the chance to dim the pendants give energy saving of 68%. The cases where both the ceiling light and the pendants can be dimmed result in energy saving from 2-37%

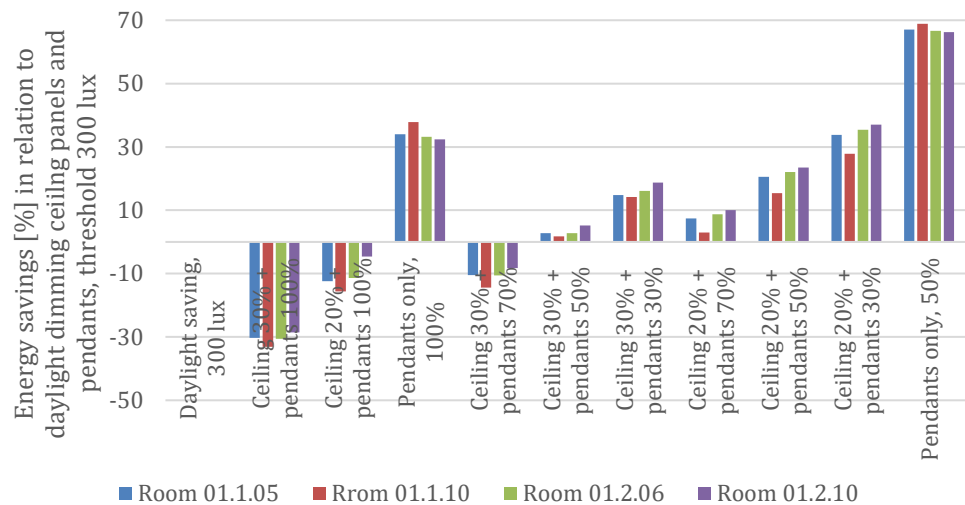

Figure 6.28: Energy savings [%] in relation to daylight saving threshold 300 lux, for the 11 different cases.

Measurements

A tridionics system logged the dimming percentage of the different control-groups. In total 5 channels registered the behavior of the luminaires. The ceiling panels, channel G1-G3, can be activated with changes in daylight levels and movement. The switch on occurrence is registered.

It has been a challenge for the project group to understand the output of the measurements. Based on input from the manufacturer the different channels would represent the following:

- G0 represents the sensor itself – activated or not
- G1 represents the zone in the back of the room
- G2 represents the zone in the middle of the room
- G3 represents the zone in the front of the room
- G4 represents the pendants (always on)

Daylight harvesting

As described in the manual from the manufacturer

(http://www.luxomat.com/dk/pdf/dk/ba/MAN_PD4-M-DAA4G-DK_komplett.pdf)

, the daylight control is ideally based on the illuminance reading in the back of the room. For the case in Frederiksbjerg School, the variation in daylight will be very small from the middle to the back of the rooms, due to the 9 m deep rooms. Hence, it is not expected to see a high variation in light output in the room, due to registered variations in daylight levels.

For a day in March the dimming percentages for the ceiling lighting in room 1.1.05 are rather constant throughout the hours of the teaching day; 33% for the zone in the back of the room, 30.5% for the zone in the middle of the room, to 29% in the front of the room. Those dimming percentages corresponds to off-sets of 8% and 12%, which is in line with the manufacturers default off-set of 10% and 15% for the two zones.

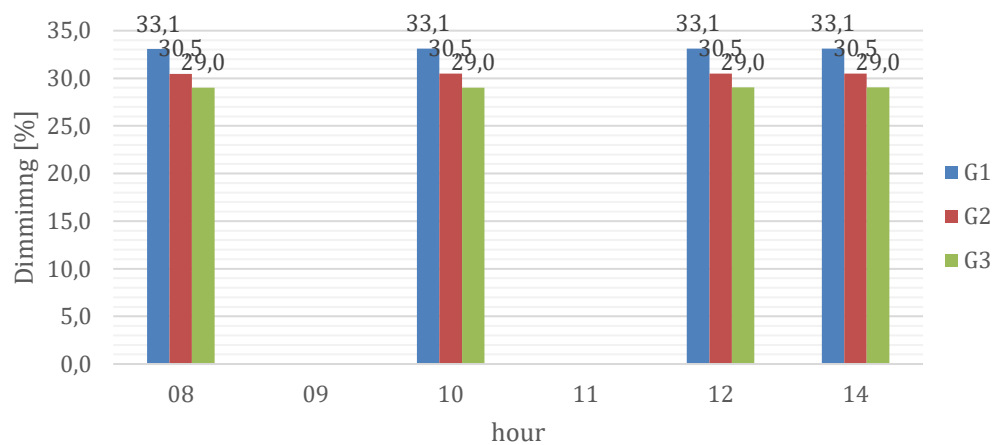

Figure 6.29: Dimming percentages for the ceiling lighting in room 1.1.05

From the measurements we do also see variations in the dimming percentages. Which most likely can be explained by the fact that the ceiling luminaires can be dimmed by holding the switch button in.

From the measurements we can also see that when the pendants are on, the ceiling luminaires are typically off. This has been backed up by observations from the video recordings, where it can be seen that when the pendants are on the ceiling luminaires are off.

6.1.6. Conclusion

The energy calculations show energy savings by use of pendants only of up to 38% compared to the reference case with daylight savings at threshold 300 lux. Giving the users the choice to further dim the pendants 50% give energy savings in the range of 68%.

Furthermore, the calculations show potential energy savings by also giving the users the opportunity to dim both the ceiling lighting and the pendants, the saving potential is in the range from 2-37%.

The measurements of dimming values of the ceiling luminaires, show values in the range of 30%, which correspond to the observed light measurements. However, the measurements also show variations in the dimming values.

6.1.6.1. Sound data

As in paragraph 2.6.2.4 described, we recorded the noise levels in our four classrooms during the entire two-times-two Wednesdays and Thursdays 90-minute educational sessions. And also made time-lapse videos of these sessions at the same time, so we could evaluate afterwards what activities had taken place during the 90-minute sessions. As we are interested in comparing noise levels as a measure of behavioral change, we eventually narrowed down our sound timeslots to those moments that pupils were doing one type of activity: working from their educational books, in small groups or by themselves, in the

general area of the classroom. The teacher was present helping individuals, but not actively in teaching voice.

Preparation of timeslots

We started with the possibility of 48 timeslots, each 90-minute long. After reviewing our time-lapse video, we narrowed these down to 38 timeslots of varying length (approximately between 20 and 40 minutes) where the type of activities took place as described in our four classrooms.

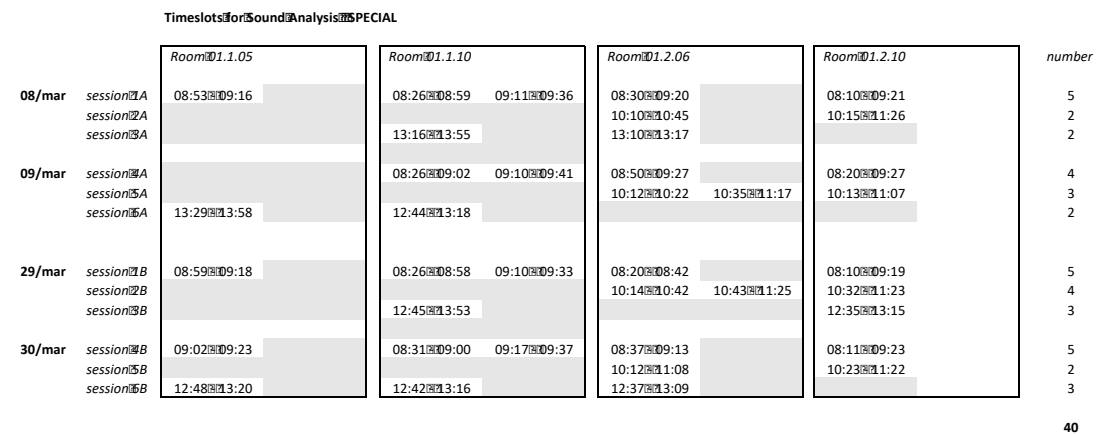

Figure 6.30: Timeslots with comparable pupil activities

For each of these timeslots we cut-out the corresponding sound recording from our bigger data files, and processed these to find average, minimum and maximum A-weighted equivalent sound pressure levels.

Comparable timeslots

To enable us to compare the average (A-weighted equivalent) sound pressure levels recorded during exposure to the default lighting versus the new lighting meaningfully per timeslot, we needed to include more parameters to approach “comparability” of timeslots. We used the following parameters:

- number of pupils present in the general area of the classroom,
- the weather (or daylight presence),
- and how the lighting system was used in each timeslot.

In order to establish these, we cut-out all 38 timeslots from our larger video files and re-looked at these again and made notes regarding these parameters. In addition, we looked into our collected data about the indoor climate, as well as observation notes to ensure no significant external interference had took place during a timeslot (e.g. construction noise, alarm etc). We collected this data together in one-page overviews per timeslot (Fig. 6.31).

TIMESLOT 01

Room 01.1.05	OLD LIGHTING	Session	1A	Sound		Light		Indoor Climate	
Wed 08.03.2017	08:53 – 09:16	Group	Panda	dB average	51,0	Lux average A	1132	CO2 average	645
Weather	Overcast Sky	Activity	Book work	dB min	35,0	Lux average B	70	Temp average	19,82
Light scenario	Ceiling ON	No of Kids	8 - 10	dB max	74,4			Humidity average	33,75

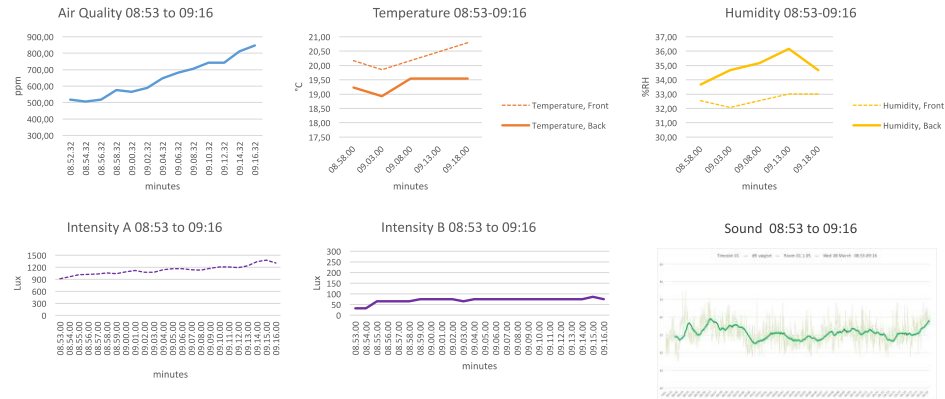

Figure 6.31: Example of collected data for timeslot 1

Our next task was to find out which of these 38 timeslot datasheets we could compare to each other to review if there was a significant change in pupil noise production between the two different lighting scenarios. These overviews helped us to eventually select 20 comparison scenarios, in which we compared the average (A-weighted equivalent) sound pressure levels of one or multiple timeslots with each other. Two comparisons are shown below as an example in figure 6.32 (*indskoling*) and figure 6.33 (*mellemtrin*):

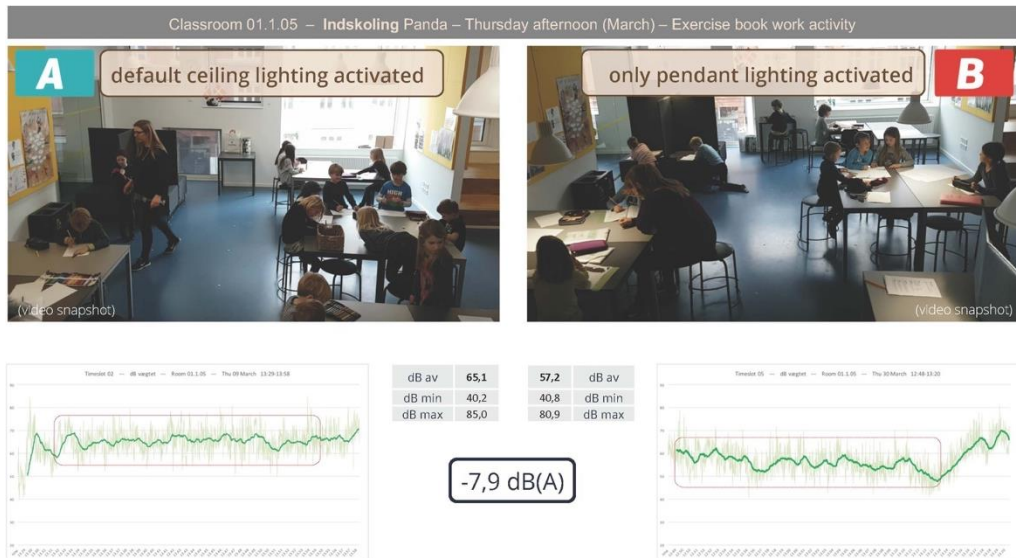

Figure 6.32: Timeslot dB comparison example Indskoling

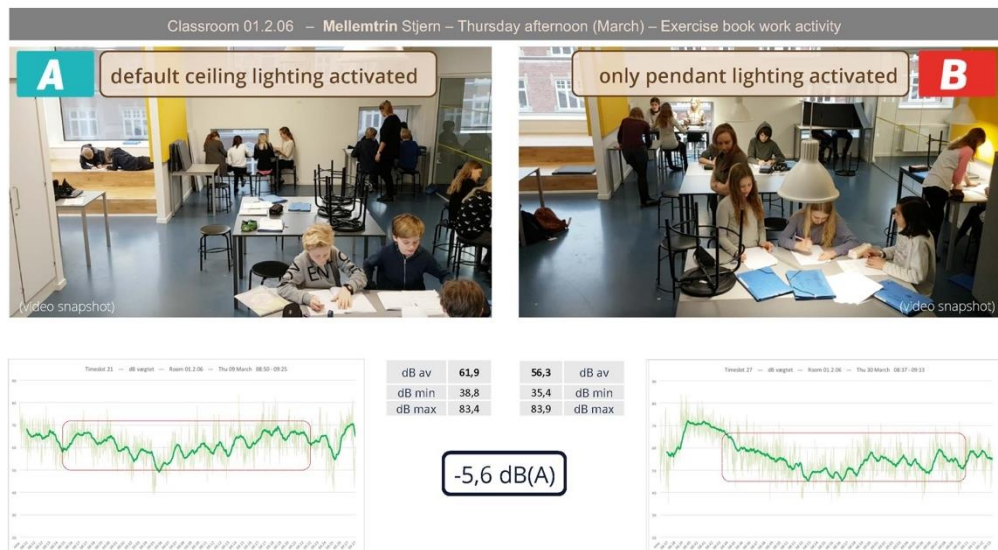

Figure 6.33: Timeslot dB comparison example Melletrin

Analysis

So far, we have compared the A-weighted equivalent sound pressure levels in decibel (dB) for these 20 scenarios. By setting 1 dB as a noticeable difference (JND) (ISO 3382-1, 2009) and 3dB as a significantly noticeable difference to the average human ear (table 6.3), we were able to classify our 20 scenarios, and found 14 improved noise conditions with the new high-contrast lighting, 4 cases within the JND, and 2 cases getting noisier than original as shown in Fig. 6.34. Of the 14 improved conditions, 11 cases show an audible improvement between 1 and 3 dB, and we found 4 cases with more than 3 dB, which is regarded as a significant improvement.

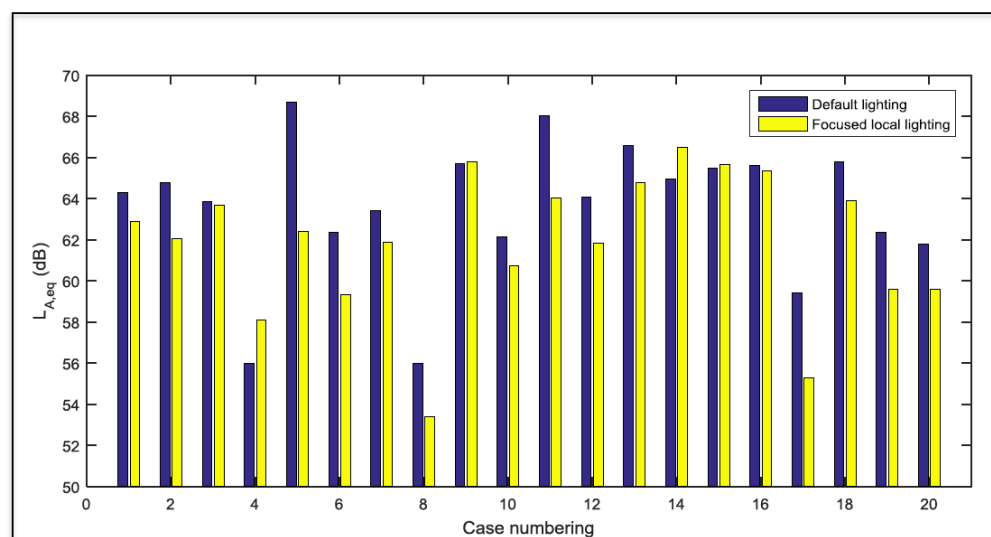

Figure 6.34: Twenty case comparisons of average measured sound pressure levels (Figure 5 from the Euronoise paper).

Difference in dB	
< - 3 dB	Very significantly noticeable
-3 < -1 dB	Just noticeable
-1 < +1 dB (JND)	Non-audible
+1 < +3 dB	Just noticeable
> +3 dB	Very significantly noticeable

Table 6.3: Sound noticeability

The sequence of the light distribution tested could influence the results. With the original lighting tested first followed by the new lighting, there are 3 improved noise case (42%), 2 neither better nor worse (29%), and 2 worsened cases (29%). With the new lighting first and distributed lighting later, the improvement was much more significant: 9 out of 10 cases were improved, 1 case unchanged. Therefore, it should be concluded that the order of lighting exposure could affect the performance as well.

For the key stage 1 activities, the average reduction in noise level becomes 2.2 dB, whereas the key stage 2 activities have a slightly lower reduction of 1.4 dB, although the difference between 1.4 and 2.2 dB should not be said to be significant. The arithmetic average noise reduction across the 20 cases including the worsened conditions is found to be 1.7 dB, which seems to be significant enough in an overall sense.

6.1.7. Conclusion

The noise levels during focus-based activities were measured in a Danish primary school with different lighting conditions. Comparing 20 fair conditions in terms of activity type and number of students, we found that the noise levels of the 70% of the measured cases get lowered, which potentially implies that the students can focus on the class better, and accordingly the students learning could be higher. The average improvement in the noise level was not huge, but clearly above the perceptual noticeable difference.

6.1.8. References

ISO 3382-1 (2009), ISO 3382-1: Acoustics - Acoustics -- Measurement of room acoustic parameters - Part 1: Performance spaces, 2009.

6.1.8.1. Results from performance tests

The tables below show results from objective measurements during the intervention weeks in the time of the performance tests. The results indicate that the lighting level was significantly higher in the condition with pendants. CO₂ concentration is rather stable across the intervention. The indoor air temperature measurements were corrupted in many cases but there is no reason to believe that they were not in the same magnitude.

Room 01.2.06					
		Class B		Class J	
		Ceiling Panel	Suspended Luminaire	Ceiling Panel	Suspended Luminaire
Logger		Mean ± SD (Min, Max)	Mean ± SD (Min, Max)	Mean ± SD (Min, Max)	Mean ± SD (Min, Max)
LUX	B	127 ± 130 (97, 151)	799 ± 51 (162, 850)	172 ± 17 (65, 194)	723 ± 90 (65, 829)
	C	164 ± 8 (140, 172)	521 ± 22 (452, 560)	169 ± 24 (22, 193)	647 ± 165 (43, 807)
Temperature	D	-	-	-	-
CO2	E	1024 ± 37 (965, 1094)	987 ± 36 (918, 1059)	899 ± 70 (788, 1012)	988 ± 61 (918, 1094)

Room 01.2.10					
		Classroom D		Classroom A	
		Ceiling Panel	Suspended Luminaire	Ceiling Panel	Suspended Luminaire
Logger		Mean ± SD (Min, Max)	Mean ± SD (Min, Max)	Mean ± SD (Min, Max)	Mean ± SD (Min, Max)
LUX	B	255 ± 14 (172, 280)	838 ± 34 (743, 926)	355 ± 170 (86, 549)	-
	C	175 ± 9 (192, 194)	589 ± 23 (527, 635)	299 ± 84 (75, 344)	-
Temperature	D	24.2 ± 0.2 (23.9, 24.5)	-	23.4 ± 0.7 (22.3, 24.3)	-
CO2	E	1034 ± 27 (1000, 1118)	978 ± 36 (918, 1047)	1005 ± 76 (812, 11129)	-

Table 6.4: Objective measurements during tests in room 01.206 and 01.2.10.

The table below shows the statistical analysis of the pupil performance in the addition test. The overall finding is that performance in all classes seems to be improved in the condition with pendants compared to the ceiling lighting. However, the results only indicate a statistical tendency for the data to go in this direction; i.e. the differences could to some extent still be due to change/other factors, and not due to the lighting intervention.

Class (no. in sample):	B (13)	
Test:	Addition	
Samples Normally distributed (T0/T1)?	Yes/Yes	
Correct answers (avg.±std.dev.)	T0: 46,0±22,7 T1: 51,9±22,9	
Relative difference (T0-T1)	5,9 (11,4 %)	
p-value	0,04 Statistical significant	
		T0=Ceiling ; T1=Pendants
Class (no. in sample):	D (8)	
Test:	Addition	
Samples Normally distributed (T0/T1)?	Yes/No	
Correct answers (avg.±std.dev.)	T0: 44,6±16,7 T1: 40,5±16,0	

Relative difference (T0-T1)	-4,1 (-9,2 %)	
p-value	0,07 (Wilcoxon) Statistical tendency	
		T0=Pendants ; T1=Ceiling
Class (no. in sample):	J (9)	
Test:	Addition	
Samples Normally distributed (T0/T1)?	Yes/No	
Correct answers (avg.±std.dev.)	T0: 62,0±23,7 T1: 63,4±29,1	
Relative difference (T0-T1)	1,4 (2 %)	
p-value	0,24 (Wilcoxon) Not statistical significant	
		T0=Ceiling ; T1=Pendants
Class (no. in sample):	A (11)	
Test:	Addition	
Samples Normally distributed (T0/T1)?	Yes/Yes	
Correct answers (avg.±std.dev.)	T0: 22,3,0±11,7 T1: 16,6±13,6	
Relative difference (T0-T1)	-5,7 (-25,6%)	
p-value	0,09 (one-tailed t-test) Statistical tendency	
		T0=Pendants ; T1=Ceiling

Note: There is only very small absolute differences in the number of wrong answers, and no differences are statistically significant.

Table 6.5: The statistical analysis of the pupil performance in the addition test.

The table below shows the statistical analysis of the pupil performance in the creativity test. The overall finding is that performance in all classes seems to be improved in week 2 of the intervention, i.e. not following the changing of lighting condition. For all classes, except class B, the difference in correct answers is statistically significant. This could indicate that a certain learning effect was in progress during the intervention, i.e. that the pupils got better at doing the test due to repeated training. It could also indicate that the lighting condition is important cannot be ascribed to one certain condition. Further studies are needed to fully understand this mechanism.

Class (no. in sample):	B (12)	
Test:	Creativity	
Samples Normally distributed (T0/T1)?	Yes/Yes	
Correct answers (avg.±std.dev.)	T0: 58,8±25,9 T1: 61,8±26,6	
Relative difference (T0-T1)	-3 (-5 %)	
p-value	0,23 (one-tailed t-test) Not statistical significant	
		T0=Ceiling ; T1=Pendants
Class (no. in sample):	D (8)	
Test:	Creativity	
Samples Normally distributed (T0/T1)?	Yes/Yes	
Correct answers (avg.±std.dev.)	T0: 30,9±18,8 T1: 39,3±24,9	
Relative difference (T0-T1)	-8,4 (21,3%)	
p-value	0,04 (one-tailed t-test) Statistically significant	
		T0=Pendants ; T1=Ceiling
Class (no. in sample):	J (9)	
Test:	Creativity	
Samples Normally distributed (T0/T1)?	Yes/Yes	
Correct answers (avg.±std.dev.)	T0: 39,2±12,3 T1: 60,1±15,7	
Relative difference (T0-T1)	-20,9 (-34,8 %)	
p-value	0,001 (one-tailed t-test) Statistically significant	
		T0=Ceiling ; T1=Pendants
Class (no. in sample):	A (9)	
Test:	Creativity	
Samples Normally distributed (T0/T1)?	Yes/No	
Correct answers (avg.±std.dev.)	T0: 48,3,0±9,2 T1: 60,3±13,9	

Relative difference (T0-T1)	-12,0 (-19,9%)	
p-value	0,005 (Wilcoxon) Statistically significant	
		T0=Pendants ; T1=Ceiling

Table 6.6: Statistical analysis of the pupil performance in the creativity test.

6.1.9. Conclusion

For the math tests, the overall finding is that performance in all classes seems to be improved in the condition with pendants compared to the ceiling lighting. However, the results only indicate a statistical tendency for the data to go in this direction; i.e. the differences could to some extent still be due to change/other factors, and not due to the lighting intervention.

For the creativity tests the overall finding is that performance in all classes seems to be improved in week 2 of the intervention, i.e. not following the changing of lighting condition. For all classes, except class B, the difference in correct answers is statistically significant. This could indicate that a certain learning effect was in progress during the intervention, i.e. that the pupils got better at doing the test due to repeated training. It could also indicate that the lighting condition is important cannot be ascribed to one certain condition. Further studies are needed to fully understand this mechanism.

This pilot study shows the potential impact of focused lighting in classrooms for focused learning tasks, i.e. math. However, further studies are needed to get the full overview.

7. Work package 5 – Full scale test, gathering of qualitative data

7.1.1.1. Introduction

The purpose for doing qualitative research was to reveal how and why the lighting system was used during educational sessions, and to gain insight in possible behavioral effects (which might influence the pupils' ability to learn) that could be associated with particular lighting conditions. The research techniques we used to gather such data are observations and interviews and consists out of open-ended information in form of spoken (recorded) or written words or text. The analysis of this data followed the path of categorizing, and through this, the presentation of themes as an outcome. The analysis process involved five consecutive steps (Wertz, 2011):

1. cleaning and organizing the data for analysis, which involved logging the data during collection in form of notes, video and voice recording;
2. checking it for accuracy directly afterwards briefly with the respective teacher;
3. entering the data into a computer;
4. transforming this data into a format that can be categorized;
5. developing and documenting the categorization and distill into themes.

We followed this path for both our observational and interview data. By combining the results, we were able to define six themes related to pupil behavior as possibly influenced by the lighting conditions in, and particularly the way light is distributed through, their classroom. These themes suggest that spatial light distribution indeed influences the behavior of pupils, and possibly herewith their ability to learn (although the latter cannot be concluded from our qualitative data).

7.1.1.2. Classroom observations

Our observational researcher performed 12 non-participant observation sessions of 90 minutes each during which she observed the behavior of one pupil group and teacher in one classroom (see schedule below). During these sessions she did not interfere with or manipulate the events (classroom activities) and subjects (pupils and teachers) being observed, but just observed as an outsider.

Day	Timeslot	Level	Classroom	Group
Wednesday				
Session 1	08:00 – 09:30	Mellemtrin	2A	Delta
Session 2	10:00 – 11:30	Mellemtrin	2A	Charlie
Session 3	12:30 – 14:00	Indskoling	1A	Panda
Thursday				
Session 1	08:00 – 09:30	Mellemtrin	2B	Nordlys
Session 2	10:00 – 11:30	Mellemtrin	2B	Jupiter
Session 3	12:30 – 14:00	Indskoling	1B	Isbjørn

During each session the observer logged notes on an observation template. To guide our observer's attention, the template included four categories:

- Activity log and the perceived atmosphere. This category covers notes about what the general (educational) activity of pupils and the teacher in the classroom is at a certain moment in time or during a timeslot, and what kind of atmosphere this radiates as recognized through the emotional sensibility of the observer (e.g. lively, focused, intimate, chaotic, passive, active, sleepy, cheerful, energetic, etc.)
- Noise log: although we recorded the sound levels in the classroom during each session (see paragraph 6.5), we also made notes about significant or changes of internal (inside the classroom) and external (outside the classroom) noise. This would enable us to connect certain positive or negative sound level peaks to certain events (e.g. a teacher or pupil shouting, loud laughing, construction works outside, traffic etc). And secondly, to understand and recognize communication styles, e.g. groupwork requires discussion thus talk, whereas individual work requires silence. This would also help us to interpret our recorded sound data.
- Movement log: the observer tried to log how often pupils would get up and walk around or leave / enter the classroom. During the initial group interview with the 6 teachers prior to our studies, we learned that some forms of movement are disturbing and / or a sign of low concentration. Less movement could mean better concentration. It should be noted though that a pupil getting up to pick up a pencil or such from a cupboard to continue his/her work afterwards is not regarded as disturbing, but part of the activity ongoing. Thus we only logged those “movements” that were not related to the educational activity.
- Lighting log: we also noted down the time that the (electrical) lighting was changed (switched on or off, dimmed etc), so that above mentioned observations could be linked to the corresponding scenario of lighting condition present during a certain timeslot or entire session (if the lighting did not change).

After each session our observer quickly browsed through her notes and spoke with the responsible teacher for 5 to 10 minutes about those observations she noted but was not sure if interpreted correctly.

In addition to taking notes, our observer also video recorded all 12 sessions. This allowed us during the analysis of the data collected on our note templates, to re-view certain events and look more detailed at specific occurrences or behaviors again.

7.1.1.3. Interviews

Interview research is essentially a way of collecting qualitative and quantitative information by questioning a person or a group of persons (Wertz, 2011). Our aim with this research technique was to gather in-depth information about the (both practical and emotional) experiences of the teachers and pupils with the lighting conditions in their classroom, and (from their view point) its influence on their behavior and wellbeing (e.g. their actions, mood, motivation, concentration, distraction, happiness, alertness, etc). In order to gather such information, we structured the interviews around three topics:

- Practicalities of the lighting system: e.g. ease of use of each system; when to use what type of lighting; visual and physical (dis)comforts;

- Classroom atmosphere: the kind of atmosphere they experience as a result of a lighting scenario; its likability, the noticeability of changes in the lighting conditions, and any other positive and negative experiences and feelings they might have;
- Pupil behavior: discussing any noticed changes in behaviors, moods or motivation; and in particular discussing a possible change in distraction versus concentration levels of pupils in the classroom due to the lighting scenario active.

We interviewed our six teachers (Heidi and Trine, indskoling and Kristian, Thomas, Ulla and Matthias at melletrin - matematik) three times: once as a group before commencing our studies, once individually towards the end of study 1, and again individually towards the end of study 2. This structure allowed us to interview teachers before any intervention took place, once after using one lighting scenario, and next the other scenario. The two pupil groups (both Melletrin) we interviewed took place during the last 10 minutes of two observation sessions during study 2.

7.1.2. Group interview

Our group interview with the six teachers was firstly aimed to learn more about their experience with their current classroom design, and in particular the lighting conditions, prior to doing any intervention. We were interested to find out what the current pros and cons were, and what in their perspective could be improved. Our second aim was to present our planned intervention (adding focused light pendants) and to get their feedback on their willingness to use it, their first thoughts on when or how they might want to use it, and their preferences in terms of positioning (i.e. furniture layouts etc).

The group interview was scheduled to last about 45 minutes. To guide this session, we prepared a short interview guide with a list of open-ended, probing questions and distributed A4 printed hand-outs describing our planned intervention. The interview guide allowed for space to make quick notes of responses and thoughts directly during the interview, but each interview was also voice-recorded so that we could listen back and refine our notes made during the interview.

7.1.3. Individual interviews

The following 12 individual interviews were scheduled in agreement with each teacher either during lunch break or in the afternoon after their last teaching session and were agreed to take about 20-25 minutes of their time. These took place in each teacher's respective classroom, with the relevant lighting scenario activated so that we could discuss it whilst experiencing it.

To guide our individual interviews, we developed an interview template based on the three topics described above, which we adapted slightly to address experiences with respectively the default lighting and new the lighting systems. We used a semi-structured interview approach that included mostly simple open-ended questions that interviewees could relatively easily understand and answer, but also allowed the interviewer to have freedom to probe into answers and adapt to different interviewees and situations. In addition, we added sometimes a few questions about observations made during their teaching sessions. Both to clarify the observer's interpretation, as well as to gain greater insight in the phenomena observed.

7.1.4. Pupil interviews

In addition to interviewing our teachers, we also had the opportunity to conduct two 15-minute group interviews with two melletrin pupil groups that were included in our research. As these opportunities only arose during our presence as an observer in the classroom, we did not prepare a specific template prior but used our teacher interview templates to probe these pupils with questions. These sessions were also recorded for further analysis afterwards.

7.1.5. Follow-up interviews

We collected our (group and individual) interview data during January to April 2017. The experiences and thoughts of those interviewed were consequently based on a relatively short period of use and exposure. When the teachers and school requested to keep the new lighting system in place after we finished study 1 and 2, we were able to return approximately six months later (October 2017) to re-interview our teachers (5 out of 6) individually again, but now to gather their insights from having used the new system for a much longer period of time, and during a variation of educational activities and seasons. We used the “new lighting” template to conduct these interviews again and added some additional questions per teacher to follow up on their answers given or observations made during our first set of interviews.

7.1.5.1. Results

Our observations and interviews provided us with insight into how and why the lighting system was used in certain ways during the educational activities we observed. And secondly, the potential behavioral effects of different lighting conditions.

7.1.6. Lighting application

Our observations and interviews revealed three principal forms of educational activities:

- **tutoring time**: takes place most often in the instruction area, where the teacher tutors the entire group of pupils seated on the podium. Little movement of pupils, beyond toilet visits, are noticed.
- **exercise time**: takes place throughout the entire classroom but predominantly in the general area of the classroom. Pupils are seated as they like – at tables, on the floor, in the windowsills, etc), and movement of pupils is limited to toilet visits, taking utensils from wall cupboards, and consulting the teacher / fellow pupils;
- **“free” time**: can take place anywhere in the classroom as well as outside with no pre-defined seating positions. Free time includes activities pupils undertake when they have finished their “official” exercise work for that session (e.g. individual, social or artistic activities) or during a scheduled alternative exercise (mostly at *indskoling* level where the relative young pupils need sufficient alteration between work and play time). A significant amount of movement within or in/out of the classroom may be present.

Our observations and interviews also revealed the following “typical” configurations of (de-) activation of the two types of electrical lighting (ceiling luminaires and/or pendant lighting) during an educational activity:

- During tutoring time either no lighting is activated and the teacher and pupils rely on natural light to illuminate their space (particularly when the smartboard is in use), or only the ceiling lighting is activated. This was also the case during those sessions where pendant lighting was available. It appeared to be preferred to only have gentle, uniform background lighting present and avoid distractions (e.g. by the brighter pendants);
- During exercise time the ceiling lighting was almost always activated during those sessions when the pendants were not available. Both to ensure good visibility for all pupils spread throughout the space as natural light does not reach the back of the classroom, as well as to keep pupils “awake” and actively working, according to the teachers. When the pendants were available, they were activated almost always first – and following with or without the ceiling lighting activated. In principle it was found preferred to only use the pendants during these timeslots to create a more intimate and focused atmosphere. But in some circumstances the teacher did activate the ceiling lighting (completely or at a dimmed level). For instance, when they noticed a few pupils working in relative “darkness” (when not enough seats at the pendant tables were available) or when daylight was very limited and not penetrating into the classroom, e.g. during gloomy, rainy or cloudy days.
- During free time the ceiling lighting was almost always activated; both during sessions with and without the pendants available. These educational activities generally don’t require traditional learning behavior (e.g. concentration), but rather an environment to nurture other behaviors such as social interactions, creativity, and/or physical activities. Occasionally also tables and seats were moved around, which made most pendants not even useful anymore. They might even become an obstacle, when hanging too low and pupils or the teacher could bump into them.

Based on the above described “lighting system” use, it became apparent that we needed to particularly investigate possible effects of lighting conditions on pupil behavior during the exercise time-slots. These activities required evident “learning” behavior as well as use of the general area of the classroom (where the new pendants were installed). The following paragraph describing behavioral effects emerging from the qualitative data are therefore mostly relevant for these forms of activity.

7.1.7. Behavioral effects

The result of our qualitative data analysis related to pupil behavior following the steps described in paragraph 5.1, is the definition of five themes: attraction, focus, attention, movement, and adaptivity. These themes are describing perceived changes in pupils’ behavior which could possibly have occurred due to the presence of lighting pendants which, when activated, create a non-uniform spatial light distribution in the classroom.

- **Attraction**

Our four classrooms exist out of three areas (see also paragraph 3.3.3): the “general area” (for small-group and individual work) – here is the new pendant lighting installed, the “instruction area” (for group instruction and smartboard use), and the “special area” (for particular tutoring to selected pupils). The respective teacher of each pupil group and/or classroom made a seating-schedule indicating which pupil to sit where when doing their (individual) exercise work. But in practice it appeared that pupils are relatively free to move and go sit where and with whom they wish spread out throughout the classroom

and nearby hallway. Besides sitting at the larger group tables or smaller individual tables in the general area, some pupils preferred to sit on the podium in the instruction area, the floor or couches, or even in the windowsills.

One behavioral change that emerged from our qualitative data relates to seating preferences. When the new lighting pendants were present in the classroom (type B), the majority of pupils seemed to be inclined to sit at the tables close to them in comparison to the default situation (type A) where they were more scattered around. This effect seemed stronger when the pendants were also activated. It seems therefore that pupils might be “attracted” by the pendants, and even more when these pendants are active, creating obvious “pools of light”.

“.. The pupils really like to read close to the lights. They often ask me if I can switch them on” (Heidi, teacher indskoling)

When discussing these observations with our pupils, it appeared they intuitively associate this type of lighting with the safe and comfortable atmosphere of their home décor. Most of them expressed to feel more at ease when sitting near pendant lighting when doing their (paper-based) exercise work. It was also discussed whether the pendants were too bright possibly, as they are suspected just above eye-height and the light source is relatively close. But the pupils and teachers found them to be comfortable.

“.. I do not feel blinded by the light, it makes me feel relaxed” (pupil, melletrin)

However, we also noticed that a minority of pupils still chose to sit away from the new pendants when they were activated. Their motivation for moving away was that they preferred a more subdued and shielded place to work, whereas the pupils sitting around the tables with the pendants preferred being amongst each other in brighter circumstances.

“.. I think it is really nice that there is not so much light everywhere. Now I can choose where I like to sit” (pupil, melletrin)

The above observations suggest that having pendants (as objects) suspended above working tables in the classroom influences pupil behavior as to placement and comfort. Firstly, they predominantly attract pupils towards them. Hence, they end up seated more closely together in small groups around the pendants and are less scattered around. However, at the same time activating the pendants creates a greater diversity of light conditions within the same learning space. This allows pupils to select their own comfortable micro-working environment available (respectively brighter or darker area) closest to their preferences at that moment in time. And thirdly, the particular type of luminaire we selected, a pendant, is a familiar object for most pupils and associated with the comfort feeling of their home décor.

- **Focus**

Following the first theme, when pupils flock more towards the tables underneath the pendants when activated (type B), they end up working on their educational exercises in the context of small groups. Today’s educational philosophy encourages pupils to co-work and learn from each other instead of consulting the teacher primarily. By working

in small groups, this ambition is encouraged as it becomes more natural for pupils to collaborate together. Our qualitative data suggests also that the pendants seem to strengthen an inward focus within the small groups, and lesser interaction with groups/pupils outside their direct circle. This seems to lead to less classroom disruptions (e.g shouting or walking around to others further away) and possibly better concentration. It was also noticed that those pupils who deliberately choose another area to sit and work, also feel more comfortable to work by themselves at that moment. The opportunity to have both with in the same space, co-working in small groups as well as doing individual work, without disturbing one another too much is regarded by the teachers as a positive effect.

".. I am not sure if the new lights have improved the concentration of the pupils, but I did notice they focus more on themselves and local neighbors instead of the rest of the room" (Mattias, teacher Melletrin)

The above observations suggest that having pendants (as objects) suspended above working tables in the classroom influences pupil behavior leading to less disturbance.

- **Attention**

One of our aims to investigate how a learning environment (and in particularly the lighting conditions) impacts pupil's ability to learn, is to explore its influence on how well they are able to concentrate or pay attention to the task at hand. Although most teachers "suspect" that the concentration of their pupils improved, our interviews and observations do not provide strong enough data to claim a direct linkage. But there are possibly linkages, e.g. less disturbances might lead to better concentration, and being more comfortable in an environment might also improve one's circumstances to concentrate (both described above) that suggest an indirect effect.

".. I think the concentration is better in my room now. I feel that I do not have to walk around so much to assist pupils individually" (Ulla, teacher Melletrin)

".. I am not sure if the new lights have improved the concentration of the pupils, but I did notice they focus more on themselves and local neighbors instead of the rest of the room" (Mattias, teacher Melletrin)

One observation that came forward more strongly in support of this theme, is that matematik teachers noticed that active pendants seemed to have particularly a calming effect on those pupils with apparent concentration "problems". These pupils are generally more prone then others to be distracted or being disruptive themselves. The teachers noticed these pupils "concentration" behavior (in this case, having their attention on their workbooks) changed more significantly then they could confidently say for the "average" pupil.

- **Movement**

A fourth observation is that active pendant lighting seemed to discourage pupils to "get up and walk" during exercise time, in comparison to those sessions with the default ceiling lighting activated. There was agreement among the interviewees that movement of pupils to visit the bathroom and to grab utensils from wall cupboards and such very likely are not affected (as these are necessities), but other "forms" of movement such as to

interact with a friend at another table or to visit the teacher, might have decreased when the pendants were activated. There is no quantitative data such as counting movements throughout a session to support this potential effect, but teachers had this impression it might. If indeed true, general agreement was that this was found a positive effect during exercise time when (individual) concentration is required and restlessness or distraction discouraged. It was however not deemed relevant or even disliked during free time, as social interaction, activity and creative are then the key objectives for “learning” and moving around to interact with others is regarded positive behavior.

- **Adaptivity**

The last theme covers room appearance and consequent perceived atmosphere. Our data indicates that the new lighting system allows for greater variation in the appearance of each classroom. The new lighting system with pendants is agreed to be an “easy” tool to quickly alter the room’s atmosphere in support of a (particular) educational activity. It also allows the teacher to respond more actively to seasonal and weather differences (which impact daylight and sunlight presence), as well as to the general mood of the pupils (e.g. sleepy, overly-active, bored, etc) that day.

“.. I like that we do not have the lighting on all the time. I or the pupils can make some changes, that work best for mood of my pupils that day” (Christian, teacher Melletrin)

This implies that both the practical use of the lighting system (e.g. to increase the amount of light if too little natural light is present or vice versa) but also a more “human centered” use to provoke or change a certain mood by varying the lighting conditions and herewith the classroom’s atmosphere. Examples of the latter are for instance increasing the brightness of the ceiling lighting and deactivating the pendants when pupils appeared quite sleepy. This was thought to awake their alertness. Or activate only the pendant lighting when the pupils appeared overly-active. This was considered to have calming effect. Having to option to adapt the lighting for both practical and mood reasons was regarded worthwhile by the teachers and pupils.

For this theme to last long-term and not to be forgotten, the lighting system needs to be easy to use by the teachers without much prior explanation. They already have a high workload during their educational sessions. Thus, for them to actually use the possibilities of the lighting, it needs to be simple and straightforward. Only then the lighting can become an active tool, and not just a gimmick unused. We found that our system was still very much in use six month after our actual studies. Teachers (and pupils) found it easy to control (simple wall switches) but most importantly, did not forget about it as the pendants are obviously present though non-obtrusive objects in their classroom environments. Simply said, they are evident so one does not forget to use them.

7.1.8. Conclusion

Based on the above described results in form of themes, it may be concluded that the new lighting system (with pendant lighting) provokes (favorable) changes in pupil behavior during exercise time activities. These changes appear to be instigated by two characteristics. Firstly, the pendants’ physical identity. Pendants appear to be familiar and recognizable objects that most of our subjects were familiar with from the home décor. They are associated with certain form of usage, being positioned above a table

(working) surface, and a rather intimate atmosphere. Because of this, these pendants presence already seem to evoke a change of behavior. Secondly, the appearance or the light itself that activated pendants typically create: relative bright, local pools of light. These brighter pools of light lead to stronger contrasts within the relatively weaker lit surrounding classroom environment. The consequence of activating the pendants is that the relatively uniform appearance of light in the classroom (as a result of the default ceiling lighting) changes to a form of non-uniform appearance.

The above learnings imply that the type of non-uniform distribution of light that we created in our studies with pendants influenced our pupils' behavior in various ways (as described by our five themes) during certain curricular activities (exercise time). In paragraph 2.1 we described that in order for us to "measure" a change in pupils' behavior relevant to learning, we could investigate changes in five behavioral agencies. With our qualitative research results, we may discuss our results in respect to four of these:

- The first agency, engagement, seems to benefit from our non-uniform spatial light distribution design. Themes attention and focus relate closely to this agency. These two themes suggested that pendants (as objects and/or activated) influence pupils' behavior so that they make less disturbances. And secondly it is suspected that this type of lighting improves pupils' ability to concentrate, but this cannot be concluded directly from our observations. It can however be more confidently argued it has a particular calming effect on those pupils with apparent concentration "problems" and that their attention level changed notably.
- For the second agency, social behavior, positive changes are also noticed. The theme attraction describes that having pendants suspended above working tables in the classroom influences pupil behavior as to placement as they attract pupils towards them. The theme focus described that those pupils sitting at the tables underneath the pendants, work more often in the context of small groups and collaborate more together within their table group. The agency movement also touches upon social behavior, describing that activated pendants seem to provoke less interaction between groups of pupils at different tables, but more within a group. This was considered a positive effect for those activities requiring a calm and concentrated atmosphere. Whereas deactivation seemed not to impact movement and interactions continued to take place as in the pre-study situation, which is considered positive behavior during certain educational, social and creative activities as learning with and from each other is an important cornerstone of today's teaching philosophy.
- The third agency, affect, relates to changes in mood and/or motivation of pupils. Also, these appear to be favorably influenced. The theme attraction described that pendants provide comfort as pupil's associate pendants with the comfort feeling of their home décor. And secondly, because they create a greater variety in lighting conditions within the same classroom, they enable pupils to choose a place with lighting conditions close to their own preference. It is suggested that when pupils emerge in more comfortable environmental conditions, they feel more at ease and motivated to work on their exercises. The theme adaptation describes amongst others a "human centered" use of the new lighting system. By varying the activation of available ceiling and/or pendant luminaires, the teacher may provoke a mood

(change), e.g. calming or activating effect, in their pupils in support of the educational activity at hand.

- The fourth agency, visual (dis)comfort, is not much addressed by our qualitative data, but in general both pupils and teachers did not find the new pendants to be bothersome. The brightness of the light sources (which are relatively close to the eye) as well as the pools of light falling on the table surfaces were regarded within normal visual comfort conditions. The physical presence of the pendants was also considered acceptable, only during those few occasions that tables and seats were moved around and pendants floating freely in the air, was considered unpractical. Thus, a type of pendant luminaire that can either to be put up temporarily or removed, would be ideal.
- The fifth agency, attainment (or academic performance as measured by standardized tests) is not covered by our qualitative research.

Although we may be able to conclude from our qualitative data research that our form of non-uniform lighting design provoked the (favorable) changes in pupil behavior, it is not viable to conclude that “any” form of non-uniform distribution of light will incite similar results. As we only tested one type of non-uniform light distribution with one typical luminaire, a pendant, further studies are recommended to explore different designs and luminaires and their impact on pupil behavior before concluding there is a direct relationship.

7.1.8.1. References

Wertz, F.J., Charmaz, K., McMullen, L.M., Josselson, R., Anderson, R., McSpadden, E. (2011). Five ways of doing qualitative analysis. The Guilford Press. ISBN 978-1-60918-142-0

8. WORKPACKAGE 6 – Overall evaluation

8.1. Conclusion

The main findings from this pilot study show the importance of giving the users the choice to change their lighting environment so it corresponds to the learning activity. The results show both effects of improved performance in math and reduced noise level, when working in light from pendants compared to evenly distributed light from the ceiling. Furthermore the use of pendants results energy savings of up to 68%.

This pilot study shows that the distribution of lighting in rooms can have an impact on the learning environment. Further studies are needed in order to fully understand the influences and mechanisms.

Energy

The energy calculations show energy savings by use of pendants only of up to 38% compared to the reference case with daylight savings at threshold 300 lux. For the same scenario, giving the users the choice to further dim the pendants to half its output give energy savings in the range of 68%.

Furthermore, the calculations show potential energy savings by also giving the users the opportunity to dim both the ceiling lighting and the pendants, the saving potential is in the range from 2-37%.

Sound level

The noise levels during focus-based activities were measured in a Danish primary school with different lighting conditions. Comparing 20 fair conditions in terms of activity type and number of students, we found that the noise levels of the 70% of the measured cases get lowered, which potentially implies that the students can focus on the class better, and accordingly the students learning could be higher. The average improvement in the noise level was not huge, but clearly above the perceptual noticeable difference.

Students performance test

For the math tests, the overall finding is that performance in all classes seems to be improved in the condition with pendants compared to the ceiling lighting.

The differences are statistically significant for one class room meaning that the difference is very likely to be due to the different lighting conditions. Two classrooms show a difference with a statistical tendency meaning that the difference is likely to be due to the different lighting conditions, but is probably to some extent affected by other factors (e.g. mood, sleepiness, social and psychological factors). The difference in the classroom which is not statistically significant means that it cannot be ascribed to the lighting intervention.

For the creativity tests, the overall finding is that performance in all classes seems to be improved in week 2 of the intervention, i.e. not following the changing of lighting conditions. For all classes, except class B, the difference in correct answers is statistically significant. This could indicate that a certain learning effect was in progress during the intervention, i.e. that the pupils got better at doing the test due to repeated training. It could also indicate that whether the lighting condition is important cannot be ascribed to one certain condition. Further studies are needed to fully understand this mechanism.

This pilot study shows the potential impact of focused lighting in classrooms for focused learning tasks, i.e. mathematics. However, further studies are needed to get the full overview.

Illumination

When using ambient ceiling lighting alone, all classrooms achieved the illuminance values recommended in lighting standards EN12464-1 and DS700. Most of the spaces have a horizontal illuminance of 200lux or above (highest around 450lux) at the working plane. The uniformity ratio is 0.4 or higher for 63% of the cases and never lower than 0.3.

On the other hand, when pendants are part of the scenario, uniformity is below 0.2 for all cases, and illuminance levels between the pendants show 50-150lux, depending on whether ceiling lighting is ON or OFF. This means that the uniformity ratio recommended in the previously mentioned standards is not fulfilled. With pendants switched on, the children's working area has a horizontal illuminance of 500lux or more.

With pendants, a non-uniform spatial illuminance distribution is observed, creating focused bright areas where kids work and soft light between working areas, perhaps avoiding distractions from the surroundings and creating more focus on their work. With more evenly distributed lighting scenarios, no area in the classrooms stands out over another. Lighting conditions are rather uniform.

CO₂, RH and temperature

The results from the measurements of CO₂, RH and temperature show stable conditions and the effect from those environmental parameters on the students' behavior and test results was found to be insignificant.

Qualitative analysis

The results from our qualitative studies suggest that our form of non-uniform lighting design (by means of pendants) provoked changes in pupil behavior as perceived by the researchers and users (teachers and pupils) themselves. Some of these appear particularly favorable during exercise time activities. These changes can be attributed to both the physical appearance of our design (the pendants) as well as the lighting effect created by them (high contrast, local pools of light).

Although our design intervention, a non-uniform distribution of light with pendants, resulted in perceived changes in pupil behavior, it is not viable to conclude that "any" form of non-uniform distribution of light will incite (similar) changes. As we only tested one type of non-uniform lighting distribution with one typical luminaire, a pendant, further studies are recommended to explore different designs and luminaires and their impact on pupil behavior before concluding that there is a direct relationship.

8.2. Konklusion (dansk)

Hovedresultaterne fra denne pilotundersøgelse viser betydningen af at give brugerne mulighed for at vælge deres lysmiljø, så det svarer til læringsaktiviteten. Resultaterne viser både statistisk signifikante virkninger af forbedret præstation i matematik samt reduceret støjniveau, når man arbejder i lys fra pendler i forhold til jævnt fordelt lys fra loftet. Desuden resulterer brugen af pendler i energibesparelser på op til 68%.

De kvalitative undersøgelser viste, at brugen af pendlerne kan give anledning til ændret adfærd hos eleverne. Der var specielt en adfærdsændring at se, når eleverne blev sat til at løse specifikke opgaver. Brugere var så tilfredse med pendlerne, at de vil beholde dem som et permanent tiltag i deres undervisning. Dette er en positiv bekræftelse på, at den nye belysning har et positivt bidrag.

Denne pilotundersøgelse viser, at fordelingen af belysning i lokaler kan have en betydelig indvirkning på læringsmiljøet. Yderligere undersøgelser er nødvendige for at få fuldt ud at forstå indflydelse og mekanismer.

Hovedresultaterne fra projektet viser at:

1) Energibesparelse.

Der opnås energibesparelse ved at placere lyset tættere på det område der skal belyses. I dette tilfælde elevernes arbejdsborde. Vi kalder denne type belysning for fokuseret lys, og skabes typisk med pendler. Energibesparelsen er vurderet i forhold til det klassiske belysningsystem i en skoleklasse, hvor der belyses jævnt i hele klassen fra armaturer integreret i loftet. Energibesparelsen varierer afhængig af om belysningen kan dæmpes. I det scenarie hvor pendlerne er på max output opnås energibesparelse på 32-38% i de 4 undersøgte lokaler. Ved yderligere at give brugere mulighed for at dæmpe pendlerne kan opnås energibesparelser på op til 68%.

2) Ro i lokalet

Støjniveauet blev målt under både den fokuserede belysning og den generelle loftsbelysning. Ved at sammenligne 20 ens-svarende undervisningssituationer med hensyn til aktivitetstype og antal studerende fandt vi, at støjniveauet for 70% af de målte tilfælde sænkes mellem 1-6dB, hvilket potentielt indebærer, at eleverne kan fokusere bedre. Af de 14 forbedrede forhold viser 11 tilfælde en hørbar forbedring på mellem 1 og 3 dB, og vi fandt 4 tilfælde med mere end 3 dB, hvilket betragtes som en betydelig forbedring. Den gennemsnitlige forbedring i støjniveauet var ikke stor, men klart over den perceptuelle mærkbare forskel.

3) Forbedret indlæring

Indlæring blev testet i form af matematik- og kreativitet test.

Analyser af matematiktests, viser at elevernes resultater forbedres mellem 2 og 25% under fokuserede belysningsforhold i forhold til den generelle belysning. Disse resultater indikerer at eleverne får bedre testresultater under den fokuserede belysning.

Analyserne af kreativitetstests viser at eleverne både er mere og mindre kreative under den fokuserede belysning. Resultaterne fra pilot-studiet viser, at det er vigtigt at give eleverne et lys, der kan tilpasses efter undervisningssituationen.

4) Lysfordeling

Ved alene brug af loftsbelysning opnåede alle klasseværelser de belysningsstyrker, der anbefales i lysstandarderne EN12464-1 og DS700. De fleste af rummene har en vandret belysning på 200lux eller derover (højest 450lux) i arbejdsplanet. Ensartetheden er 0,4 eller højere for 63% af målingerne og aldrig lavere end 0,3.

Når pendler er en del af scenariet, er ensartetheden under 0,2 for alle tilfælde, og belyningsniveauet mellem pendlerne viser 50-150lux afhængigt af om loftbelysningen er tændt eller slukket. Det betyder, at ensartetheden, der anbefales i de tidligere nævnte standarder, ikke er opfyldt. Med pendler tændt, har børnenes arbejdsområde en vandret belysning på 500lux eller mere.

Med pendler tændt observeres en variation i rummets lysfordeling, der skaber fokuserede lyse områder hvor børn arbejder og blødt lys mellem arbejdsområder. Med det mere jævnt fordelte lysscenarie fra loftsbelysningen, er belysningsforholdene ret ensartede i hele lokalet, og der skabes ikke områder med fokus.

9. Work package 7 – Dissemination

The following list describes the dissemination done in relation to the funded project. The results are distributed among a variety of actors in the buildings value chain, and are divided in articles and conference abstracts/papers and presentations.

Articles:

- **Nye lamper i klassen sænker støjen markant**, Politikens magasin – Skoleliv, 6. december 2017.
- **Lys i øjenhøjde skaber ro og koncentration**, Case in Lysdesignbogen pp. 12., 2018
- **Akustikken i et rum påvirkes af lyset**, Byggeri + Arkitektur
- **Akustikken i et rum påvirkes af lyset**, Nyhed DTU Elektro, 29. jan 2018
- **Hjemlig belysning i klasselokaler skaber ro**, LYS 01, 2018
- **Lys er ikke bare lys**, Bygherreforeningen, 15. marts 2018, Building Green Aarhus 2018, <http://buildinggreen.eu/aarhus/2018/03/15/lys-ikke-bare-lys/>
- **Fokuseret lys sætter en dæmper på eleverne**, Indeklimaportalen, rev 15. maj 2018, <https://www.indeklimaportalen.dk/raadgivere/helhed-i-skolerenovering/fokuseret-lys-saetter-en-daemper-paa-eleverne>

Conference abstracts/papers:

- Euronoise conference Proceedings, **Noise measurements during focus-based classroom activities as an indication of student's learning with ambient and focused artificial lighting distribution** (2018)
- Proceedings article (1500 words): **PLDC** (professional lighting design conference). 1 – 4 November 2017, Paris, FR. **Design with knowledge – Light in learning environments**
- Conference abstract: **Educational Architecture – Pasts, Presents and Futures**. Danish research conference on Learning environments. 27 – 29 sept 2017, The Danish School of Education, Aarhus University, DK. **How to create the right artificial lighting conditions for educational environments?**
- Journal paper (3000 words): **Transitions** – International research conference on Innovative Learning Environments. 7 sept 2017, London, UK. **Design with knowledge – Light in learning environments**

- Journal paper (2000 words): *Kongsberg Vision Meeting* - International research conference on lighting with specific sub-topic “learning environments” at the Høgskolen i Sørøst-Norge. 24 – 26 October 2017, Kongsberg, NO. ***Lighting for learning environments***

Presentations:

- Oral presentation: *Velux Dagslyssymposium*, 2 May 2017, Berlin, GE.
- Oral presentation: *PLDC* (professional lighting design conference). 1- 4 November 2017. 1 – 4 November 2017, Paris, FR ***Design with knowledge – Light in learning environments***
- Poster presentation at *Educational Architecture – Pasts, Presents and Futures*. 27 – 29 sept 2017, The Danish School of Education, Aarhus University, DK ***Can artificial lighting play a (pro)active role in creating supportive learning environments?***
- Oral presentation: *Transitions* – International research conference on Innovative Learning Environments. 7 sept 2017, London, UK. ***Design with knowledge – Light in learning environments***
- Oral presentation: *Kongsberg Vision Meeting* - International research conference on lighting with specific sub-topic “learning environments” at the Høgskolen i Sørøst-Norge. 24 – 26 October 2017, Kongsberg, NO. ***How to illuminate learning environments well? A lighting designers' perspective***
- Oral presentation: *Frederiksbjerg skole*. Presentation of research results to entire school's teacher team. 24 October 2017, Aarhus, DK. ***Focused light in new school learning environments.***
- DR2 dagen, ***national TV-broadcast about light in schools***. Dec 21st 2017
- Oral Presentation: Realdania Indeklimadagen, 25. januar 2018
- Oral Presentation: Building Green Aarhus – ***Lys er ikke bare lys***, 18. april 2018
- Oral presentation: ***Future Trends of Architecture***, at Visions Build Future, Vienna 3. maj 2018
- Oral Presentation: ***Noise as indication of students' concentration during focus-based classroom activities: Ambient vs focused artificial lighting***, Euronoise 2018 Conference, Heraklion, Crete – Greece, 27-31- may 2018.
- Oral Presentation: Nohrcon Conference, Fremtidens skole og læringsrum. ***Lys og dagslys i skolen***, 1. oktober 2018, <https://nohrcon.dk/produkt/fremtidens-skole-og-laeringsrum-2018/kbenhavn-2018-10-01/>

10. Appendices

APPENDIX A1 Type A Luminaire

LUMITECH® LEDused III



Tilslutningsboks med driver er placeret asymmetrisk på bagsiden af panelet.

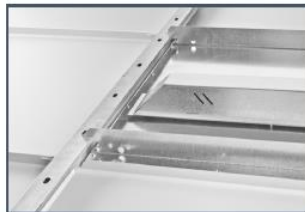

Armaturet kan monteres i forskellige typer lofter med skjult bæresystem. Ved metal 'clip-in' kassette-lofter med skjult skinnesystem skal fabrikat og type specificeres ved ordre.



Armaturet fås også i micro-prisme optik udgave (MPO)

Beskrivelse
 LED ramme er udført i ekstruderet aluminium. Ramme for skjulte lofter i stålplade. Rammer er pulverlakeret RAL 9016 glans 20-25. Optisk panel i opal dual satiné. (Akryl, PMMA).

Lysteknik
 Direkte, nedadlysende.

LED lysfarve, lysstrøm og systemeffekt
 3.000 kelvin, 2.900 lumen, 33W
 3.000 kelvin, 3.500 lumen, 40W
 3.000 kelvin, 4.300 lumen, 53W
 4.000 kelvin, 2.900 lumen, 28W
 4.000 kelvin, 3.500 lumen, 35W
 4.000 kelvin, 4.300 lumen, 45W
 RA/CRI > 80.
 Økonomisk levetid 70.000 timer L70/B10
 *1 53W 50.000 timer L70/B10
 SDCM: MacAdams 3.0

Forkobling/driver
 Elektronisk. EL, Analog 1-10V eller DALI/Switch&Dim.

Montering
 Armaturet monteres i modul 600x600 mm. lofter med synlige T-skiner eller skjulte bæreskiner. Bemærk to forskellige udgaver.

Tilslutning
 Kabelindgang gennem 2 stk. huller i tilslutningsboks placeret på oversiden af armatur, med mulighed for videresløjfning af kabler. EI-tilslutning til 3 eller 5 polet dobbelt indstiksklemrække.

Isolations- og kapslingsklasse
 Klasse I, IP44/20

Godkendelse m.v.
 EN60598-1-2. CE, T_a = +25°C

Øvrigt
 På forespørgsel kan armaturet leveres i forskellige udgaver, f.eks.:
 Andre loftmoduler
 Tunable White
 RA/CRI >90
 Klasse II
 Forberedt til stiksystemer, eksempelvis Wago Winsta eller Wieland.

	No.	Kg.	
For lofter med synlige T-skiner.			
3.000K, 2.900 lm., 33W	EL	86 46 084 123	4,8
	ED	86 46 084 440	4,8
	DALI/Switch&Dim	86 46 084 026	4,8
3.000K, 3.500 lm., 40W	EL	86 46 084 136	4,8
	ED	86 46 084 453	4,8
	DALI/Switch&Dim	86 46 084 039	4,8
3.000K, 4.300 lm., 53W	EL	86 46 084 149	4,8
	ED	86 46 084 466	4,8
	DALI/Switch&Dim	86 46 084 042	4,8
4.000K, 2.900 lm., 28W	EL	86 46 084 152	4,8
	ED	86 46 084 479	4,8
	DALI/Switch&Dim	86 46 084 055	4,8
4.000K, 3.500 lm., 35W	EL	86 46 084 178	4,8
	ED	86 46 084 495	4,8
	DALI/Switch&Dim	86 46 084 071	4,8
4.000K, 4.300 lm., 45W	EL	86 46 084 194	4,8
	ED	86 46 084 518	4,8
	DALI/Switch&Dim	86 46 084 097	4,8
Tilbehør			
Ramme for montering i fast loft	86 46 086 312	0,9	
Kasse for udvendig montering	86 46 086 309	0,9	

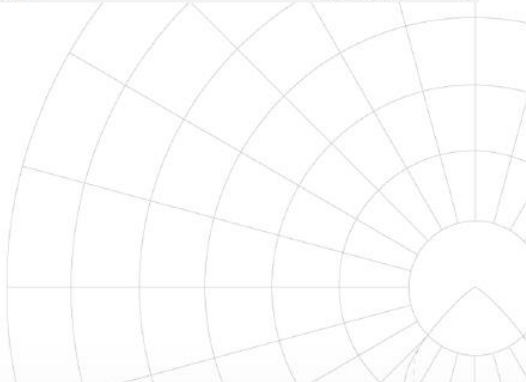

APPENDIX A2 Type B Luminaire

FAGERHULT

Printed from fagerhult.com
2016-11-29 10:59
Page 1 of 1

Dino Classic

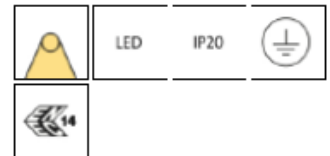

Installation
Two point suspension c/c 150 mm.

Connection
235 V integrated LED ballast. Snap-in terminal block 5x2.5 mm². 1-phase through-wiring possible. Surface mounted mains cable possible 180°.

Design
Luminaire body of aluminium in white (RAL 9016) or graphite grey textured enamel.
Ø 300 – supplied with 3,0 m white fabric cord 5x0,75 mm² and white, plastic ceiling cup.
Ø 500 – supplied with 4,0 m white fabric cord 5x0,75 mm², 4,0 m wire suspension with friction locks for height adjustment and white, plastic ceiling cup.

Dimming
DALI/phase-pulse control as standard.

Designed by
PetterssonRudberg.

LED-information
Ra (CRI) min. 80, MacAdam 3 SDCM. Driver life-time: up to 100.000 h/10 % (max failure).

Miscellaneous
Luminaire 300 mm has a switch for high/low flow. Always delivered set at high flow and need to be adjusted for low flow.

DALI/Phase-pulse control

W	Weight, kg	Diameter, mm	Colour	CCT (K)	lm	lm/W	Useful life	Art.No.
LED								
8/16	1.7	300	White	4000	716/1325	89/83	L ₉₀ B ₅₀ 55.000 h	54058-402

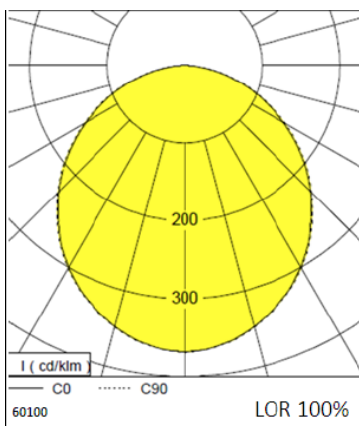
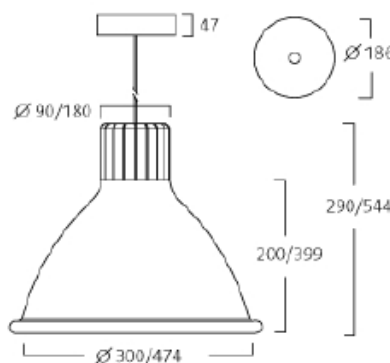

APPENDIX B LOCATION OF CLASSROOMS WITHIN BUILDING

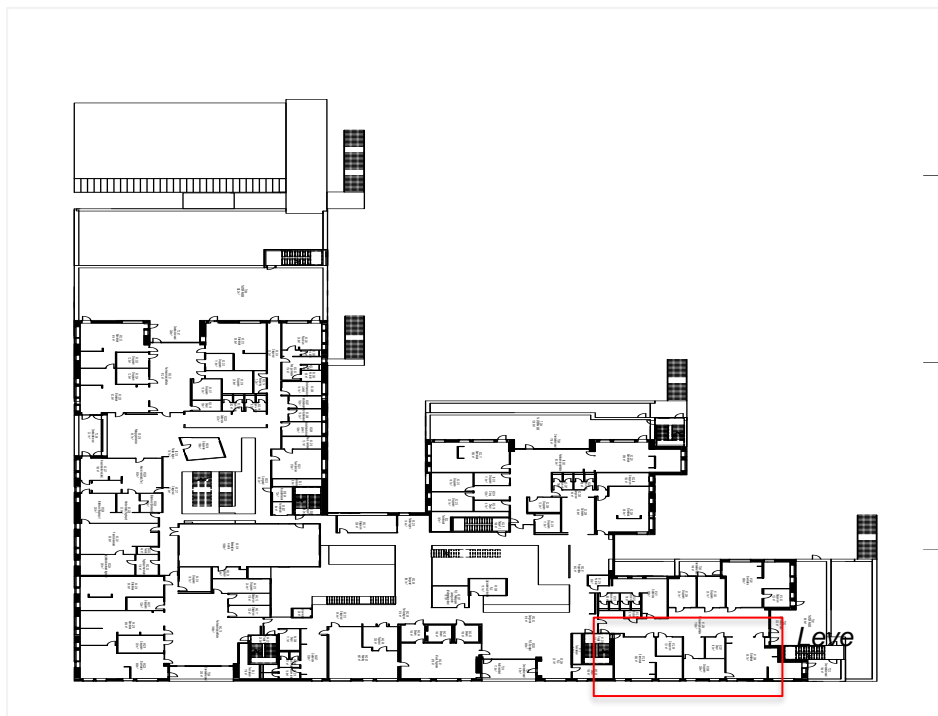
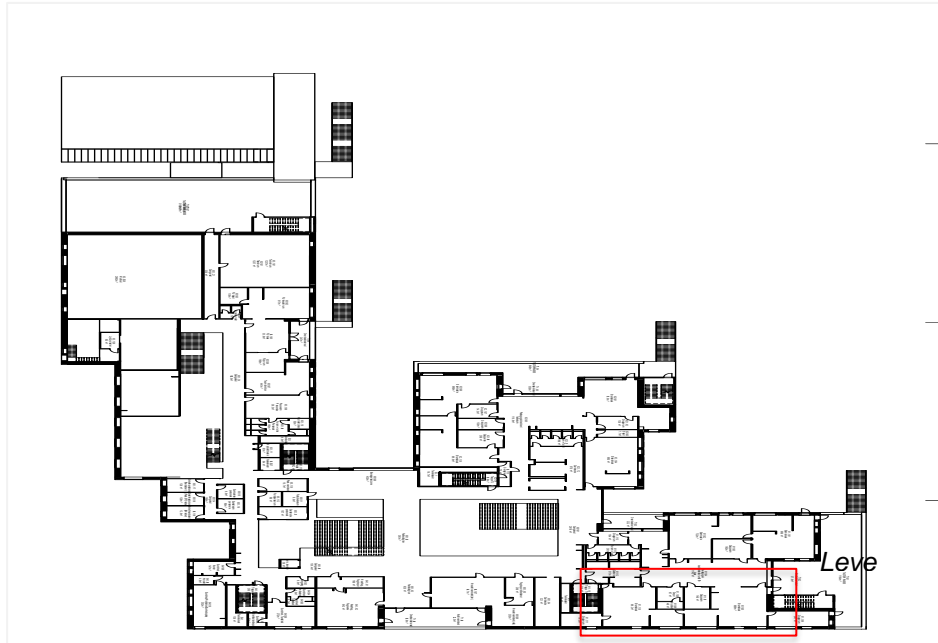

APPENDIX C DAYLIGHT SIMULATIONS INTO CLASSROOMS



Glazed Area m2 _ CLASSROOM 1A + 1B

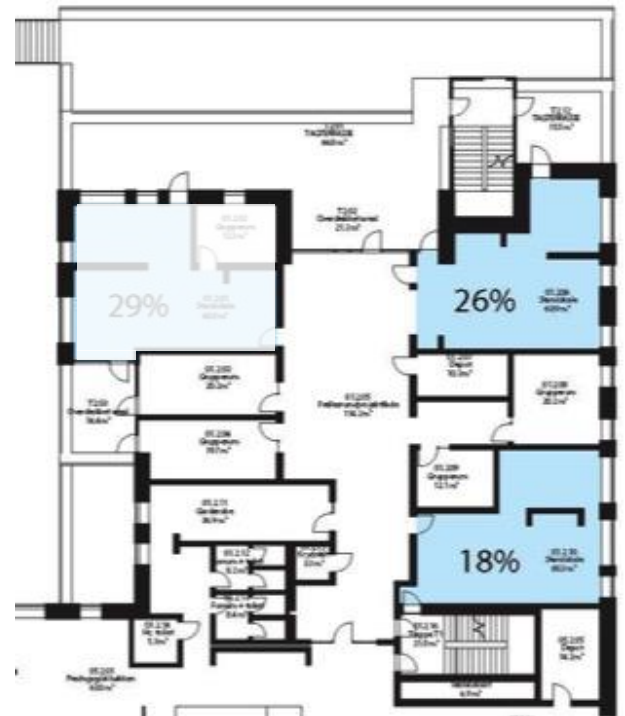

Glazed Area m2 _ CLASSROOM 2A + 2B

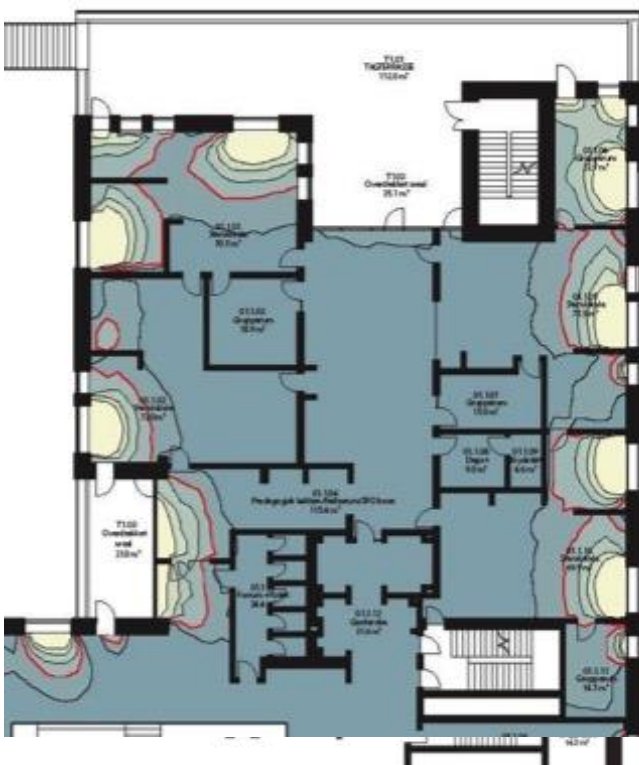

Daylight factor _ CLASSROOM 1A + 1B

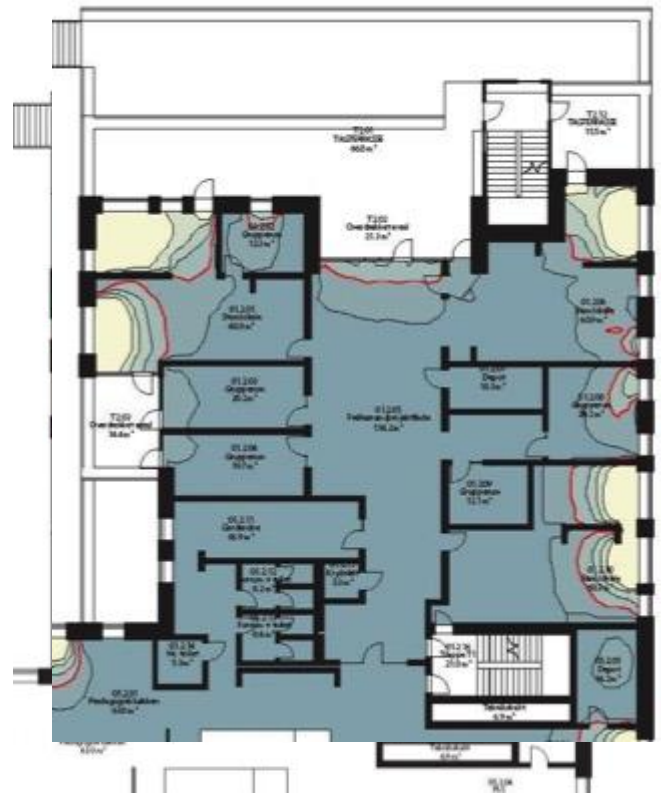

Daylight factor _ CLASSROOM 2A + 2B

APPENDIX D LIGHTING MEASUREMENT GRID

The illuminance and luminance values will be measured for each general area of the 4 classrooms for both situations: Uniformelectrical light distribution (AALD) and Non-uniformelectrical light distribution (FALD) according to the following measurement protocol:

- illuminance values according to a 1m x 1m grid at horizontal (pupil) desk height (+0.6m)
- luminance values at the 4 walls: 1m intervals at +1m, +1.5m and +2m
- luminance values of the ceiling (4 locations)
- luminance values of the desk working planes (6 locations)

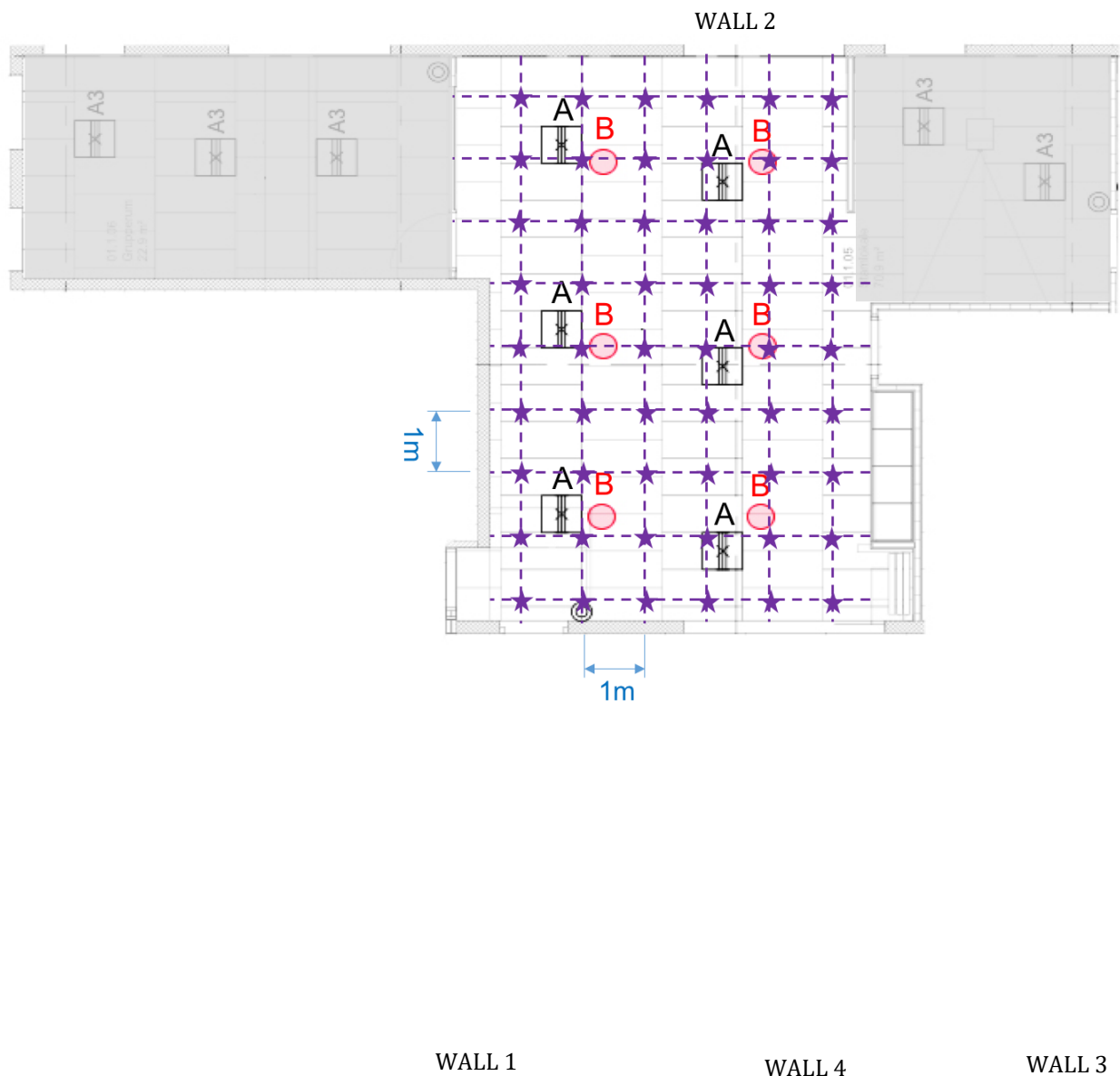

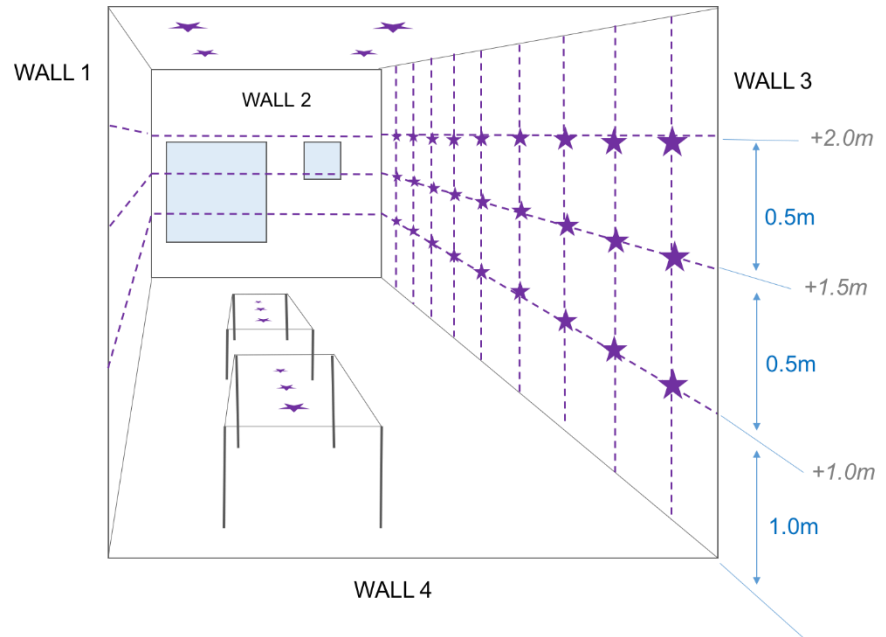

APPENDIX E Work package 4 – Full-scale test, gathering of physical data.

Illuminance hand-spot measurements

Evening-hours (only electrical lighting):

Default Scenario A – Ambient Ceiling Lighting (100%)

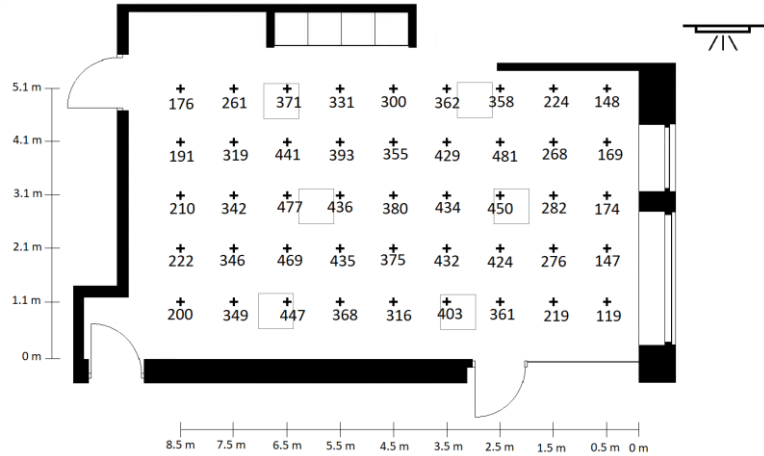

Room 1.1.10 Default Scenario – Ambient Ceiling Lighting (100%) evening-hours.

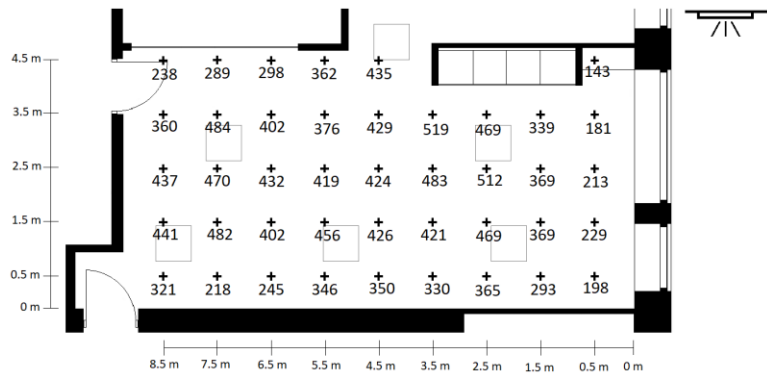

Room 1.2.10 Default Scenario – Ambient Ceiling Lighting (100%) evening-hours.

New Scenario A – Ambient Ceiling Lighting (70%):

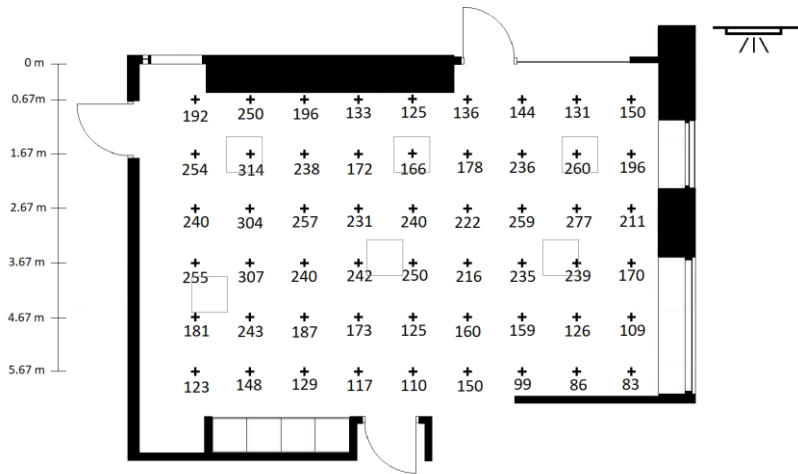

Room 1.1.05 New Scenario A – Ambient Ceiling Lighting (70%) evening-hours.
New Scenario B – Ambient CL (30%) + Focused Pendants (100%):

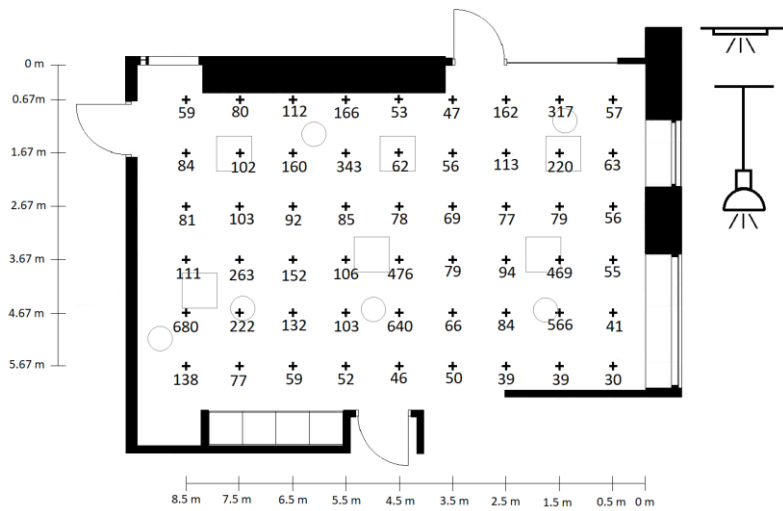

Room 1.1.05 New Scenario B – Ambient CL(30%) + Focused Pendants (100%) evening-hours.



Room 1.1.10 New Scenario B – Ambient CL(30%) + Focused Pendants (100%) evening-hours.

New Scenario C – Focused Pendants (100%):

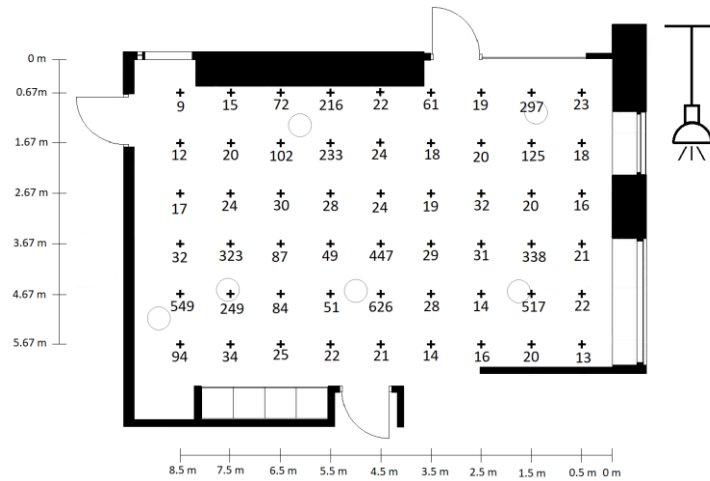

Room 1.1.05 New Scenario C – Focused Pendants (100%) evening-hours.

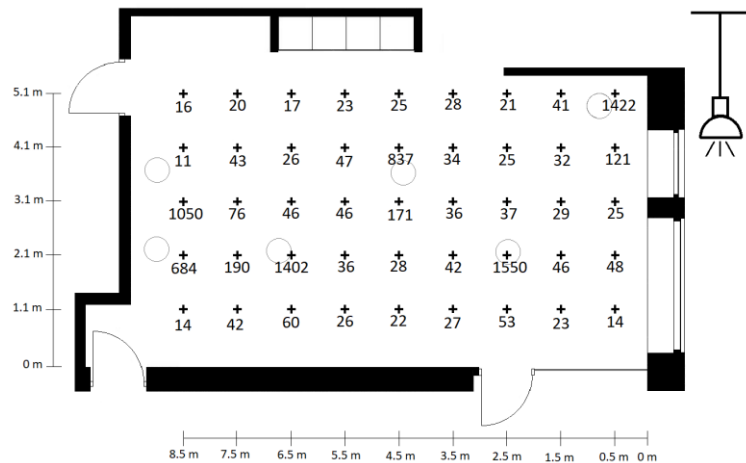

Room 1.1.10 New Scenario C – Focused Pendants (100%) evening-hours.

Daylight-hours:

Default Scenario A – Ambient Ceiling Lighting (100%):

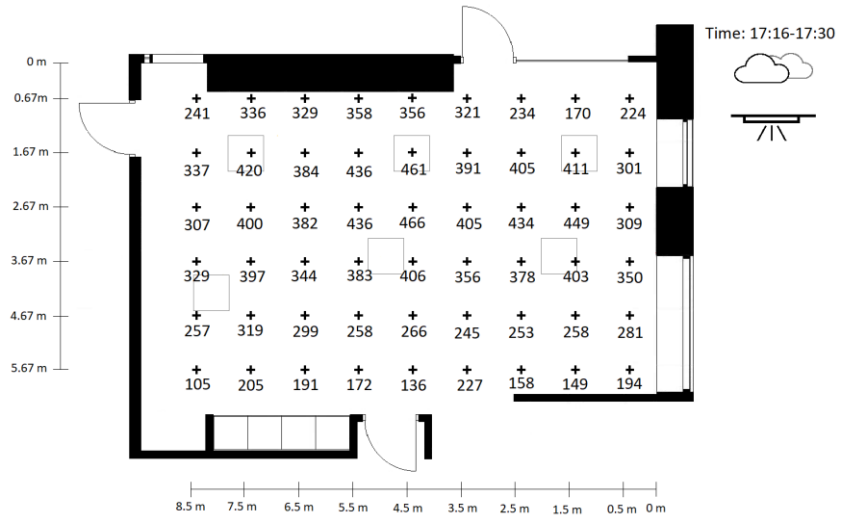

Room 1.1.05 Default Scenario A – Ambient Ceiling Lighting (100%) daylight-hours.

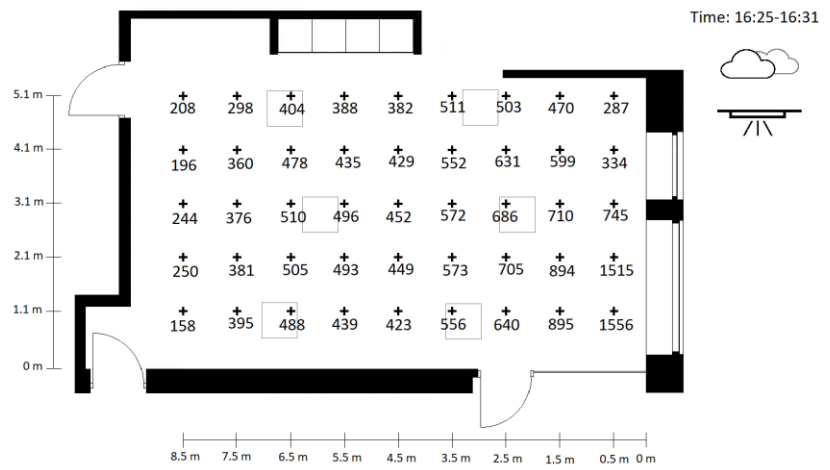

Room 1.1.10 Default Scenario A – Ambient Ceiling Lighting (100%) daylight-hours.

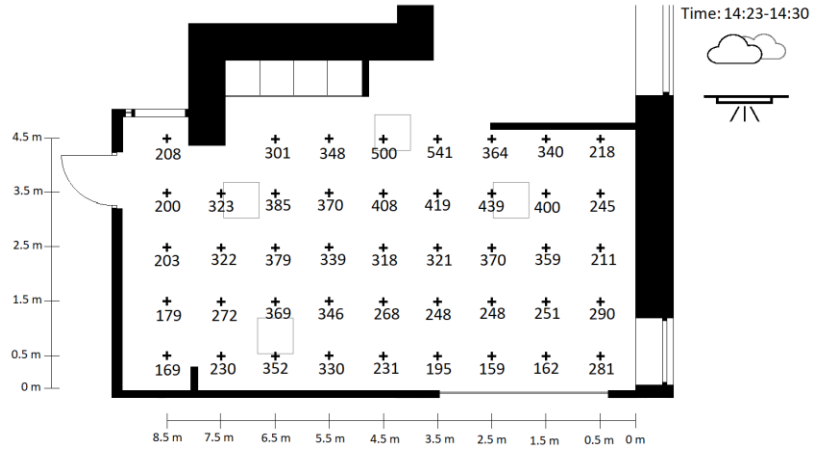

Room 1.2.06 Default Scenario A – Ambient Ceiling Lighting (100%) daylight-hours.

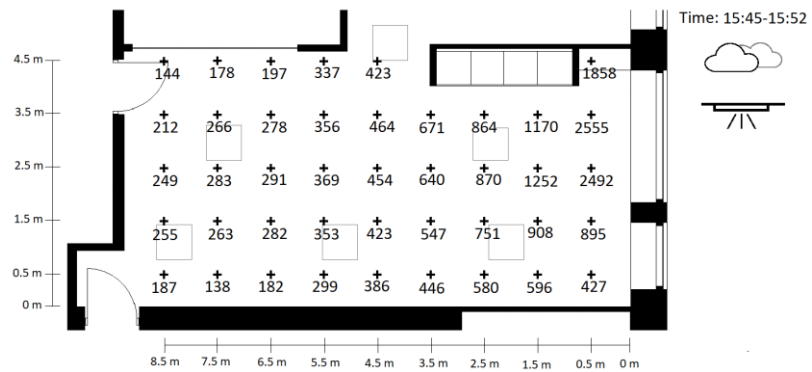

Room 1.2.10 Default Scenario A – Ambient Ceiling Lighting (100%) daylight-hours.

New Scenario B – Ambient CL (30%) + Focused Pendants (100%):

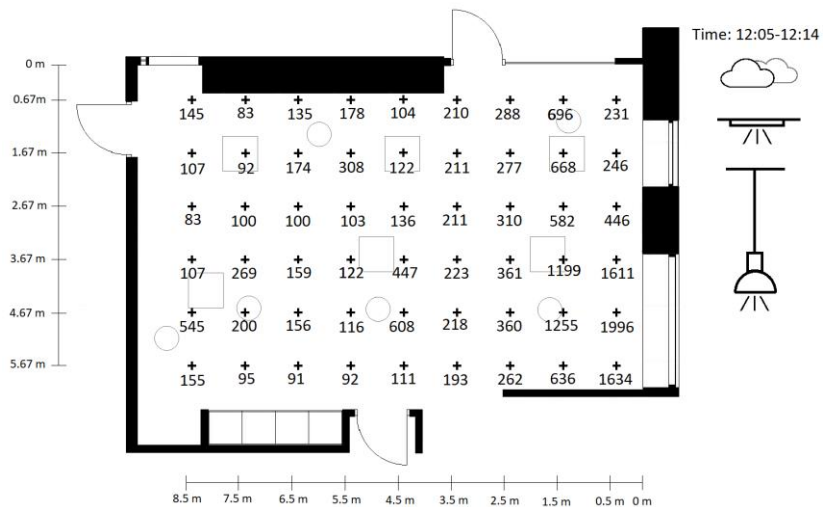

Room 1.1.05 New Scenario B – Ambient CL (30%) + Focused Pendants (100%) daylight-hours.

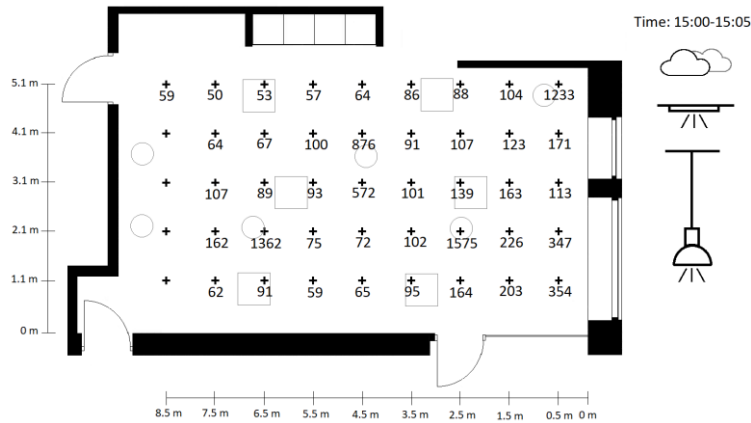

Room 1.1.10 New Scenario B – Ambient CL (30%) + Focussed Pendants (100%) daylight-hours.

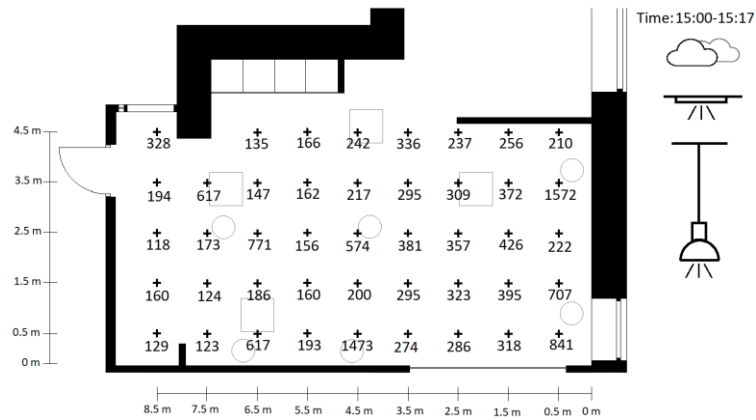

Room 1.2.06 New Scenario B – Ambient CL (30%) + Focused Pendants (100%) daylight-hours.

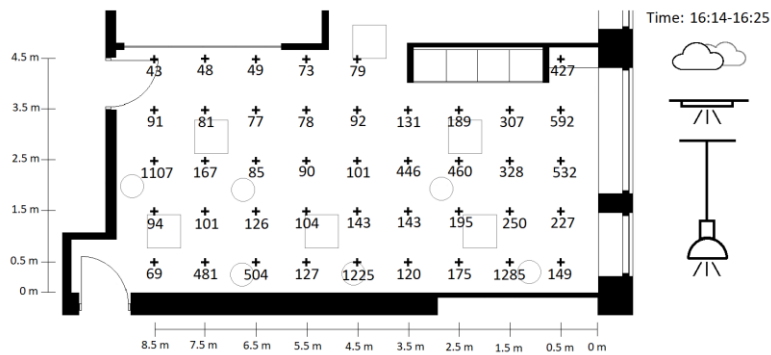

Room 1.2.10 New Scenario B – Ambient CL (30%) + Focused Pendants (100%) daylight-hours.

Lux levels from HOBO on windowsill when taking hand-spot measurements:
Hobo on windowsill in room 1.1.05

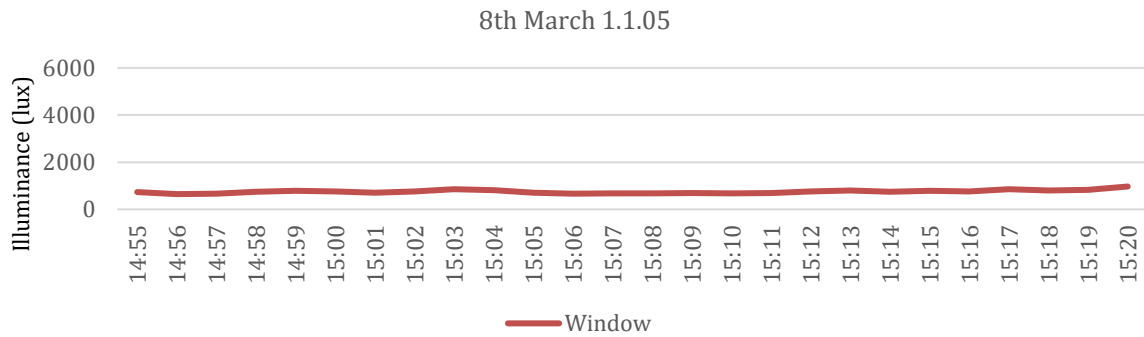
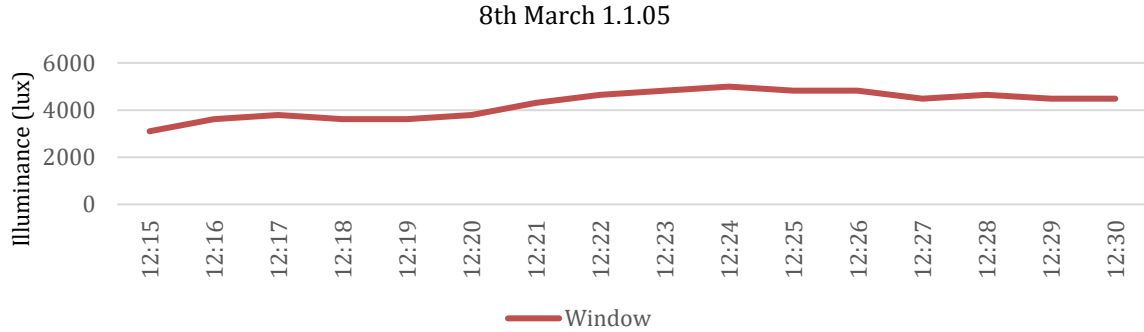

HOBO on windowsill in room 1.1.10

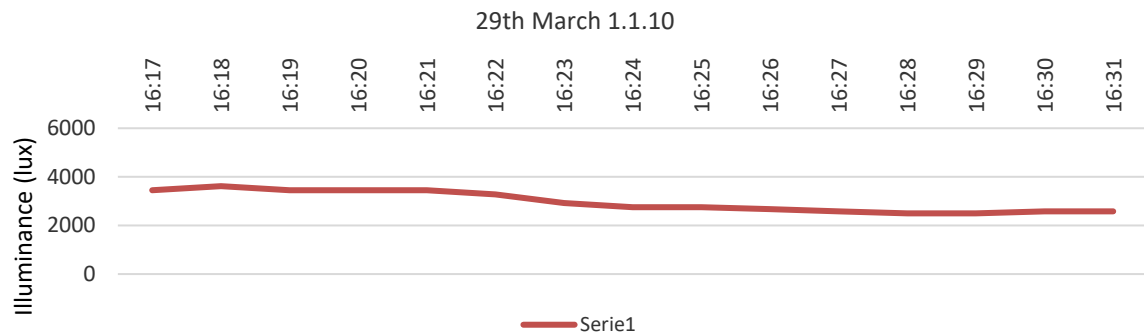
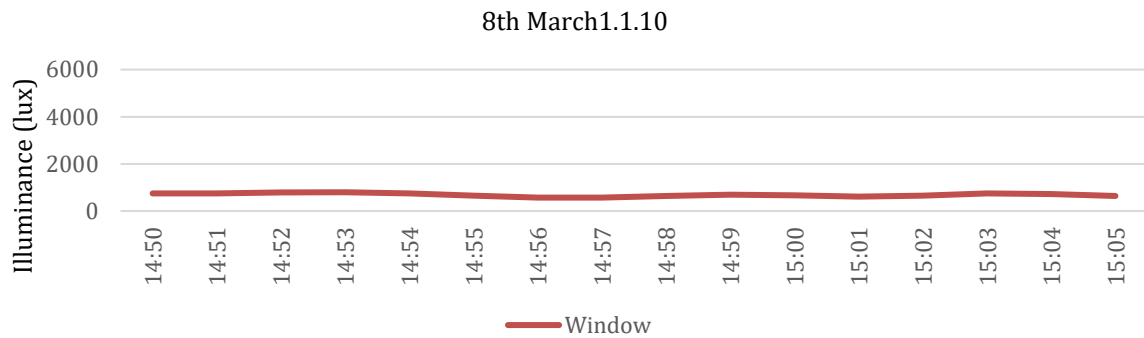

HOBO on windowsill in room 1.2.06

8th March 1.2.06

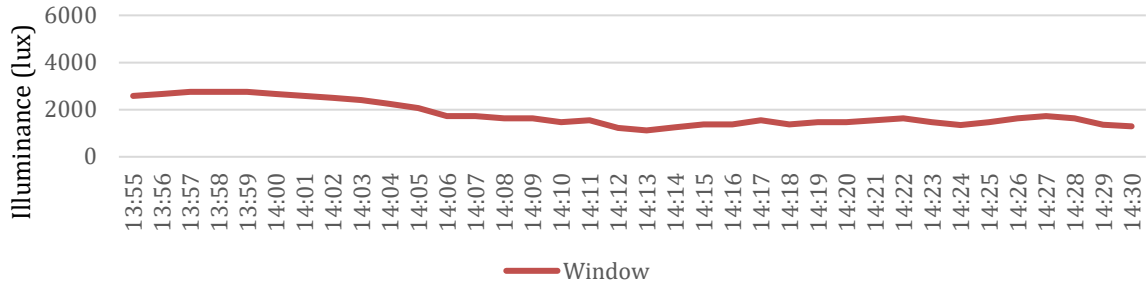

HOBO on windowsill in room 1.2.10

8th March 1.2.10

